

Create World- Class Products

sunrain

Guangdong Sunrain Air Source Energy Co., Ltd
www.sunrainheatpump.com

Air Source Heat Pump



 No.73 Defu Rd. Xingtan Town, Foshan City, Guangdong Province, P. R. of China.

 0086 757 2938 0616

 heatpump@sunrain.com

 www.sunrainheatpump.com

Air Source Heat Pump

An air-source heat pump heater (ASHP) is a system that transfers heat from air to water. Under the principles of vapor compression refrigeration, an ASHP uses a refrigerant system involving a compressor and a condenser to absorb heat at one place and release it at another place. It can be used as a space heater or cooler, and sometimes it is called a "reverse-cycle air conditioner", it is new hot water equipment with the features of safety, efficiency, power-saving, and environment protection. Usually, it uses 1 unit of electricity to produce 5 units of heat, so its COP is five times higher than the common electricity heater.

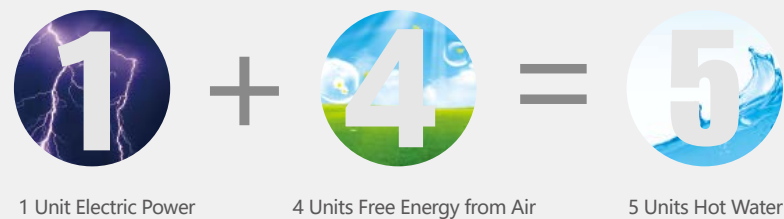

Working principle

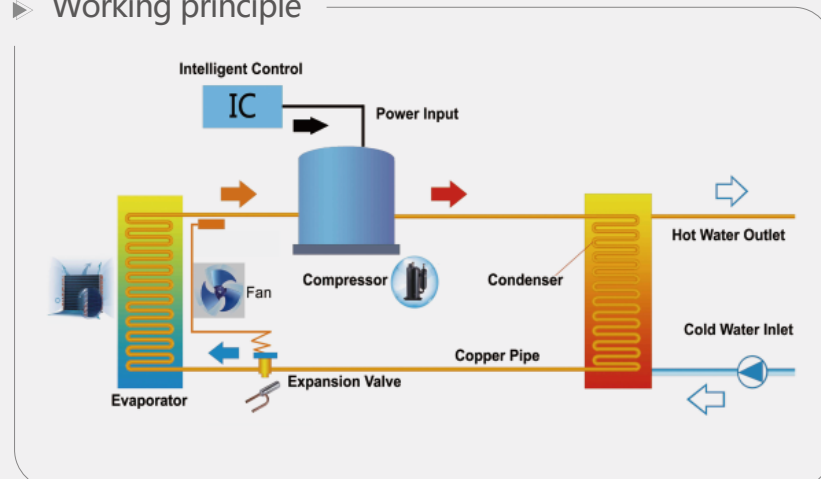

Content

PART 1 : COMPANY PROFILE

P02- P06

PART 2 : PRODUCTS

P07 - P09 Product overview

P10 - P19 Domestic hot water heat pump

P20 - P23 Commercial hot water heat pump

P24 - P43 Swimming pool heat pump

P44 - P53 Heating, Cooling and DHW heat pump

PART 3: SUCCESSFUL CASES

P54- P56

Company Profile

SUNRAIN -

Aim to give our customers the best service.



SUNRAIN Group (stock code 603366) as **Chinese largest scale supplier** of **air source heat pump system and solar water heater**, is a high-tech company which specializing in researching, manufacturing and marketing of renewable products. The business scope of the group involves **air source heat pump, pool heat pump, solar water heater, water tank, kitchen appliance etc...**, which can meet the different demands from industrial, commercial and residential application.

Production Bases



SUNRAIN Group has **5 production bases** all over China, the one located in **Shunde, Guangdong** focuses on **air source heat pump**.

This factory is over **100,000m²** with production capacity of **80,000 sets heat pump per Month**, and we have invested **USD 2 million** to build the **most advanced testing labs** which can test up to **300kW** machine under extremely cold climate down to **-30°C**.

SUNRAIN heat pump factory has got **ISO9001, ISO14001, ISO18001** and our products have been approved by **CE, Rohs, CB, SAA, ErP, etc...**

SUNRAIN always treasures the product quality and builds a complete quality management system. It controls the whole process of heat pump developing, testing, production, installation and service.

With **reliable products, customized proposals and turnkey solutions**, SUNRAIN has supported many big brands to take more share on the market.

Other Production Bases



Lianyungang Production Base
Built in 1999
 Solar heater production base
 Water Purifier production base
 Heat pump production base



Yuyao Production Base
Built in 1984
 Kitchen appliance production base
 Electric water heater production base



Luoyang Production Base
Built in 2002
 Solar heater production base



Tibet Production Base
Built in 2020
 Large flat plate solar thermal collector
 production base

Heat Pump Production Base

With a full range of heat pumps and heat pump components, SUNRAIN has built domestic heat pump production line, commercial heat pump production line, water tank production line, controller production line, metal cabinet production line and other industrial production lines. The production capacity and automation degree is in the leading position of heat pump industry.

Production lines



Enamel water tank production line: 2
 Commercial heat pump production line: 3
 Residential heat pump production line: 3
 One million sets of annual output

Advanced production equipment



Semi-automatic metal painting line satisfied reliable quality and customized color painting



Automatic cutting and stamping equipment, accurate production, safe and efficient

Advanced laboratory



- 1.Ultra-low temperature laboratory, Enthalpy difference laboratory, data monitoring center, long-term operation laboratory.
- 2.Testing temperature from -30°C~55°C
- 3.Maximum heat pump can be tested up to 300kW

Product overview

Sanitary Hot Water Series

Combo Type / All In One Heat Pump / Top or Side Air In&Out / Round Type / Square Type



200L

300L

200L

300L

200L

250L



150L

200L

250L

60L

80L

100L

60L

80L

100L

Heat Pump Water Heater / Sanitary Hot Water / Metal Case / Residential Type (P15-P17)



3.6KW / 5.4KW

7.6KW

10.8KW / 13.2KW

18.8KW

Heat Pump Water Heater / Sanitary Hot Water / Split Type (P18-P19)

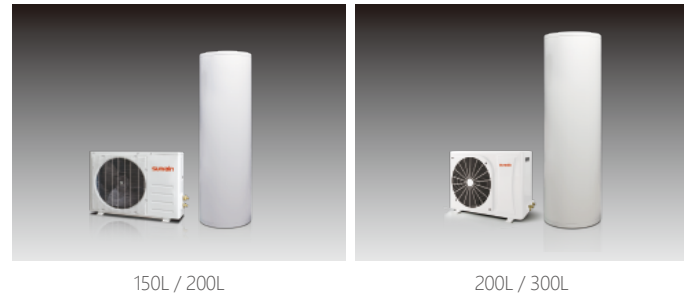

Heat Pump Water Heater / Sanitary Hot Water / Metal Case / Commercial Type (P20-P23)



Swimming Pool Heat Pump Series

Swimming Pool Heat Pump / Metal Case / Plastic Case / Residential Type / Commercial Type (P24-P39)



Swimming Pool Heat Pump / Metal Case / Commercial Type (P40-P41)



Full inverter swimming pool heat pump / Metal Case / Commercial Type (P42-P43)



Heating & Cooling & DHW Series

Multi-function Heat Pump / Heating & Cooling & DHW / DC Inverter / Residential Type (P44-P51)



Multi-function Heat Pump / Heating & Cooling / Commercial Type (P52-P53)



All In One Heat Pump

Features:

- R134a refrigerant, environmental friendly.
- CMEV: Central mechanical extract ventilation.
- WIFI smart control.
- Microchannel heat exchanger.
- Higher water temperature output up to 75°C.



Features:

- R290 low GWP(GWP=3).
- CMEV: Central mechanical extract ventilation.
- WIFI smart control.
- Energy efficient class: A++.
- Microchannel heat exchanger.

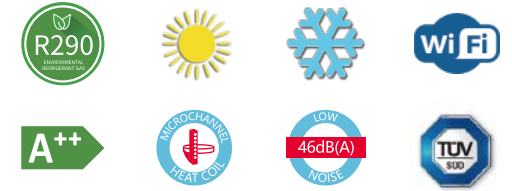

Stable silent operation

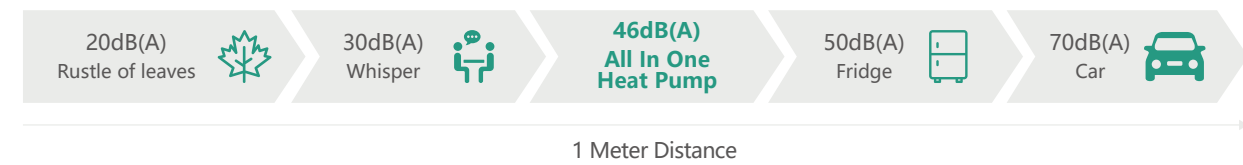

Technical Data **R134a**

Photos						
Model	YT-200TA1	YT-300TA1	YT-200TB1	YT-300TB1	YT-200TF1	YT-250TF1
Power Supply	220~240V/1/50Hz					
Rated Heating Capacity (kW)	2.4	2.4	2.4	2.4	2.4	2.4
Refrigerant	R134a					
Tapping Cycle	L	XL	L	XL	L	XL
Energy Efficient Class	A+	A+	A+	A+	A++	A++
Energy Efficient ηwh (%)	148.9	142.0	148.9	142.0	148.9	142.0
**COP (EN16147)	3.48	3.52	3.48	3.52	3.48	3.52
Tank Capacity (L)	200	300	200	300	200	250
Air Flow (m³/h)	450					
Air Discharge	Vertical					
Air Duct Diameter (mm)	φ150					
Auxiliary electric heater (kW)	2					
Default Water Temperature (°C)	55					
Working Temperature Range (°C)	-7-43					
Unpacked Dimension (mm)	Φ620*1750	Φ620*1950	Φ620*1672	Φ620*1937	600*600*1600	600*600*1830
Packed Dimension (L*W*H)(mm)	700*700*1930	700*700*2130	700*700*1790	700*700*2050	700*700*1770	700*700*2050
Net Weight (kg)	95	102	110	130	118	136
Gross Weight (kg)	113	120	125	145	137	155
Noise (dB(A))	46					

** Above results are tested at ambient temperature DB20°C/WB15°C, water temperature in 10°C/out 55°C according to EN16147:2017

Technical Data **R290**

Photos						
Model	YT-200TA2	YT-300TA2	YT-200TB2	YT-300TB2	YT-200TF2	YT-250TF2
Power Supply	220~240V/1/50Hz					
Rated Heating Capacity (kW)	2.4	2.4	2.4	2.4	2.9	2.9
Refrigerant	R290					
Tapping Cycle	L	XL	L	XL	L	XL
Energy Efficient Class	A++	A++	A++	A++	A++	A++
Energy Efficient ηwh (%)	154.5	168.7	154.5	168.7	154.5	168.7
**COP (EN16147)	3.75	3.81	3.75	3.81	3.75	3.81
Tank Capacity (L)	200	300	200	300	200	250
Air Flow (m³/h)	450					
Air Discharge	Vertical					
Air Duct Diameter (mm)	φ150					
Auxiliary electric heater (kW)	2					
Default Water Temperature (°C)	55					
Working Temperature Range (°C)	-7°C-43					
Unpacked Dimension (mm)	Φ620*1750	Φ620*1950	Φ620*1672	Φ620*1937	600*600*1600	600*600*1830
Packed Dimension (L*W*H)(mm)	700*700*1930	700*700*2130	700*700*1790	700*700*2050	700*700*1770	700*700*2050
Net Weight (kg)	95	102	110	130	118	136
Gross Weight (kg)	113	120	125	145	137	155
Noise (dB(A))	46					

** Above results are tested at ambient temperature DB20°C/WB15°C, water temperature in 10°C/out 55°C according to EN16147:2017

Heat pump Domestic hot water

Heat pump Domestic hot water

All In One Heat Pump

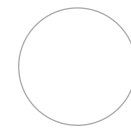

Features:

- Square and uniform design
- IPX4 class, ideal for outdoor application
- Axial ventilation design for higher efficiency
- Microchannel heat exchanger with excellent efficiency
- R134a / R290 optional
- WIFI smart control

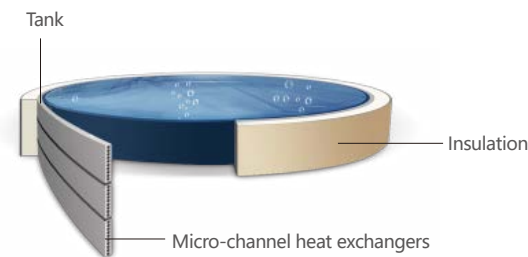

Application

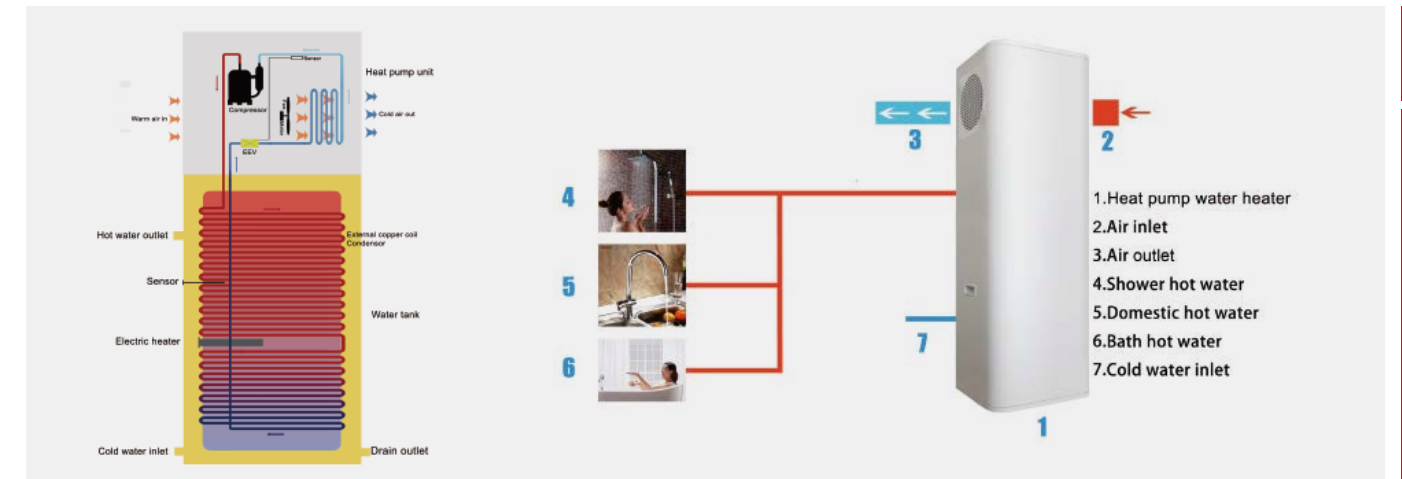

Technical Data

Photos					
Refrigerant	R134a			R290	
Model	YT-150TC1	YT-200TC1	YT-250TC1	YT-200TC2	YT-250TC2
Power Supply	220 ~ 240V/1/50Hz				
Heating Capacity at Air 20°C/15°C, Water Temperature from 15°C to 55°C					
Rated Heating Capacity (kW)	2.4	2.4	2.4	2.9	2.9
Rated Input Power (kW)	0.57	0.57	0.57	0.7	0.7
COP	4.1	4.1	4.1	4.3	4.3
Max Current (A)	15.0	15.0	15.0	16.0	16.0
Tank Capacity (L)	150	200	250	200	250
Outer Casing / Shape	Full colour painted casing / Square			Full colour painted casing / Square	
Expansion Valve	Electronic			Electronic	
Air Flow (m³/h)	450			450	
Air Discharge	Horizontal			Horizontal	
Air Duct Diameter	Non-ducted			Non-ducted	
Back-up Heater (kW)	2			2	
Default Water Temperature (°C)	55			55	
Working Temperature Range (°C)	-7-43			-7-43	
Unpacked Dimension(L*W*H)(mm)	500*500*1670	600*600*1600	600*600*1830	600*600*1600	600*600*1830
Packed Dimension(L*W*H)(mm)	640*640*1840	700*700*1770	700*700*2050	700*700*1770	700*700*2050
Net Weight (kg)	92	118	136	118	136
Gross Weight (kg)	110	137	155	137	155
Noise (dB(A))	48			48	

Wall Mounted Heat Pump

Features:

- Horizontal/Vertical optional
- Maximum outlet water temperature up to 75°C
- Multiple running mode
- Silent running, low to 38dB(A)



Technical Data

Photos						
Installation	Wall Mounted-Vertical			Wall Mounted-Horizontal		
Model No.	YT-060GV	YT-080GV	YT-100GV	YT-060GH	YT-080GH	YT-100GH
Power Supply	220 ~ 240V/1/50Hz			220 ~ 240V/1/50Hz		
Heating Capacity at Air 20°C/15°C, Water Temperature from 15°C to 55°C						
Heating Capacity (W)	600	600	600	600	600	600
Power Input (W)	169	169	169	169	169	169
COP	3.50	3.50	3.50	3.50	3.50	3.50
Hot Water Production (L/h)	12	12	12	12	12	12
Refrigerant	R134a			R134a		
Electric Heating Element (kW)	2			2		
Max Power Input (kW)	2.5			2.5		
Max Current (A)	11.4			11.4		
Water Tank Volume (L)	60	80	100	60	80	100
Max Water Tank Pressure	0.8MPa			0.8MPa		
IP Class	IPX4			IPX4		
Working temperature range (°C)	-7 ~ 43			-7 ~ 43		
Net Dimension(mm)	Φ470*977	Φ470*1142	Φ470*1282	Φ470*890	Φ470*1040	Φ470*1180
Package Dimension(L*W*H)(mm)	565*585*1010	565*585*1180	565*585*1320	565*570*960	565*570*1100	565*570*1250
Net Weight (kg)	39	42	45	39	42	50
Gross Weight (kg)	43	46	58	43	46	54
Noise (dB(A))	38			38		
Air Duct	Non-ducted			Non-ducted		

Heat Pump Water Heater / Sanitary hot water / Residential type



Features:

- R410A refrigerant, environmental friendly.
- Higher water temperature output up to 60°C.
- Tube in shell heat exchanger, Hi-COP & safe.
- With disinfection function (tank with electric heater)
- High pressure protection.
- Defrost automatically.
- MODBUS communication.
- Full automatically operation.
- Through different installation, the system can be used for cooling, heating and providing sanitary hot water.



Application

Different Way, Meet Different Demand !

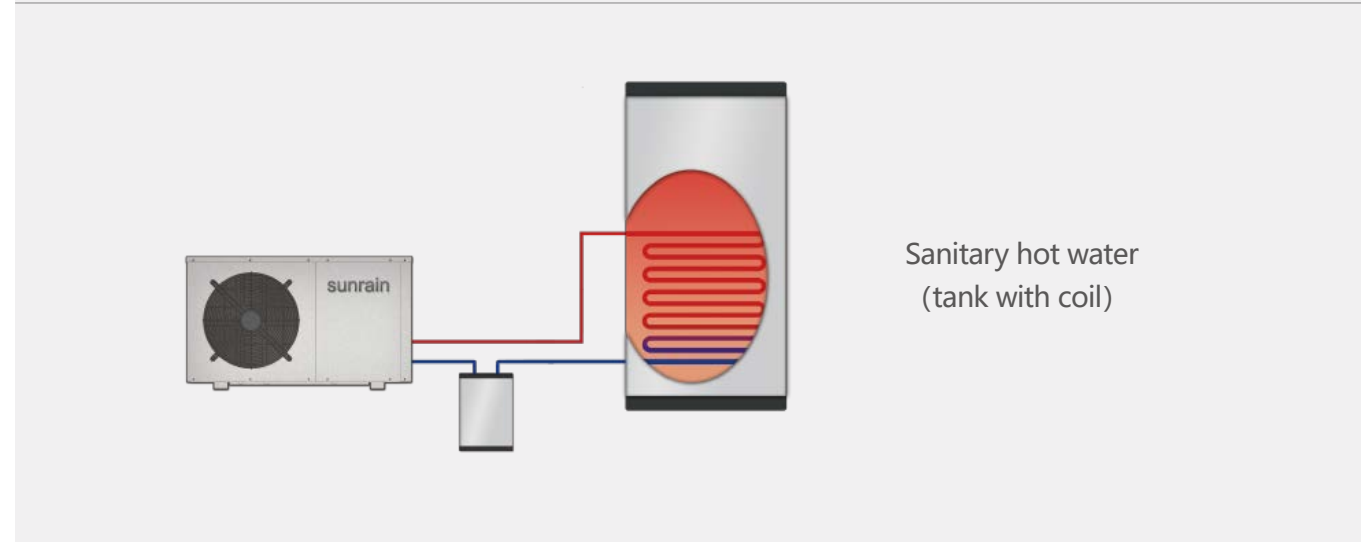
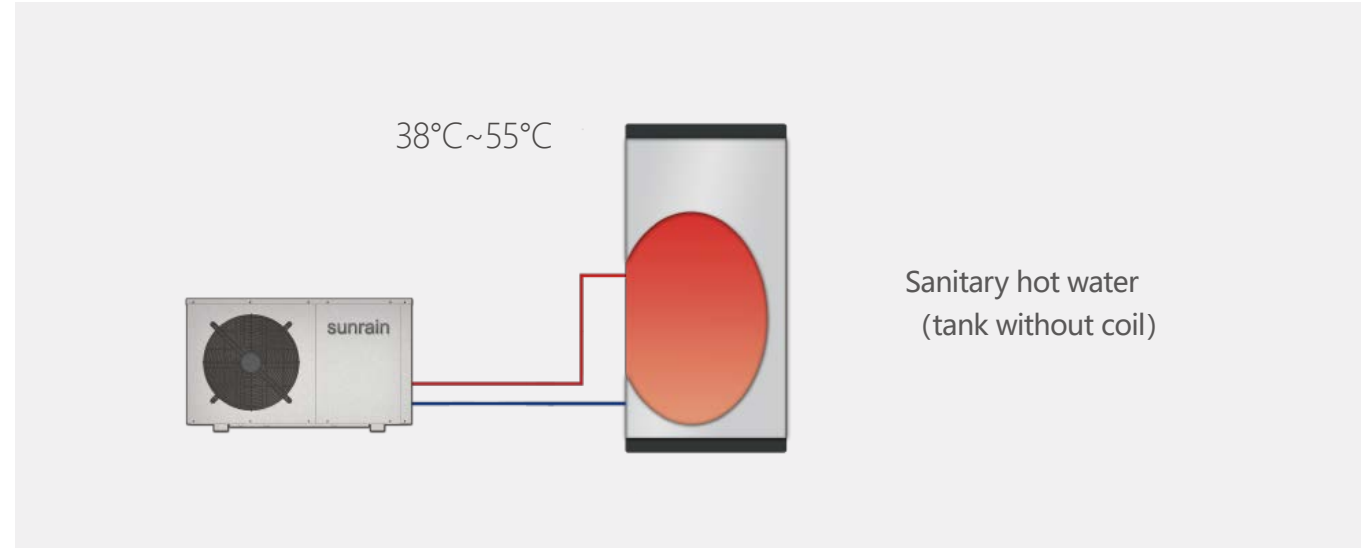

Technical Data

Photos						
Model No.	RS-004TA1	RS-006TA1	RS-008TA1	RS-010TA1	RS-012TA1	RS-018TA1
Power Supply	220~240V/1/50Hz	220~240V/1/50Hz	220~240V/1/50Hz	220~240V/1/50Hz	220~240V/1/50Hz	380~415V/3/50Hz
Heating Capacity at Air 20°C/15°C, Water Temperature from 15°C to 55°C						
Heating Capacity (kW)	3.6	5.4	7.6	10.8	13.2	18.8
Power Input (kW)	0.86	1.26	1.81	2.54	3.17	4.56
COP	4.18	4.29	4.20	4.25	4.16	4.12
Max Power Input (kW)	1.45	2.01	2.75	3.02	4.51	6.02
Max Current(A)	6.5	9.0	12.0	15.2	23.0	11.0
Rated Hot Water(L/h)	80	120	165	230	285	400
Refrigerant	R410A	R410A	R410A	R410A	R410A	R410A
Expansion Valve	Electronic	Electronic	Electronic	Electronic	Electronic	Electronic
Air Flow Direction	Horizontal	Horizontal	Horizontal	Horizontal	Horizontal	Horizontal
Water Pump inside	Yes	Yes	Yes	Yes	Yes	No
Water Pressure Drop (kPa)	35	35	40	45	45	45
Net Dimensions(L*W*H)(mm)	936*385*550	936*385*550	1011*420*614	986*420*798	986*420*798	1000*375*1320
Package Dimensions(L*W*H)(mm)	1030*445*592	1030*445*592	1105*480*657	1158*560*1017	1158*560*1017	1070*445*1440
Working temperature range (°C)	-15 ~ 43	-15 ~ 43	-15 ~ 43	-15 ~ 43	-15 ~ 43	-15 ~ 43
Noise (dB(A))	47	49	52	52	53	54
Net Weight (kg)	50	54	68	68	85	149
Water connection(mm)	20	20	20	20	20	25

Heat Pump Water Heater / Split Type



Heat pump
Domestic hot water



Heat pump
Domestic hot water

Features:

- Hi-efficient heat pump specialized compressor.
- Micro-channel heat exchangers greatly improve units performance.
- Fluorine cycle, environment-friendly refrigerant R410A.
- Less installation space, easy installation&maintenance.
- The evaporator is larger than usual size to keep its high efficiency.
- Separating the water from electricity or any other hazard material, more safe.
- Higher water temperature output max. up to 55 °C.



Technical Data

Photos				
Model No.	KFDC-70/150A	KFDC-70/200A	KFDC-100/200A	KFDC-100/300A
Heating capacity (W)	3250	3250	4800	4800
Hot water yield (L/h)	70	70	100	100
Heating Capacity at Air 20°C/15°C, Water Temperature from 15°C to 55°C				
Input power (W)	814	814	1136	1136
Rated current (A)	3.9	3.9	5.3	5.3
Max. input power (W)	2650	2650	3500	3500
Max. input current (A)	12.3	12.3	16.2	16.2
Starting current (A)	16.0	16.0	22.0	22.0
COP	3.99	3.99	4.23	4.23
Auxiliary electric heater (W)	1500	1500	1500	1500
Heating type	Fluorine Cycle	Fluorine Cycle	Fluorine Cycle	Fluorine Cycle
Refrigerant type	R410A	R410A	R410A	R410A
Noise (dB(A))	≤50	≤50	≤52	≤52
Running ambient temperature (°C)	-7~43	-7~43	-7~43	-7~43
Main Unit size (mm)	680*250*440	680*250*440	780*300*545	780*300*545
Packing size (mm)	790*355*530	790*355*530	905*380*590	905*380*590
Net Weight / Gross Weight (KG)	25/30	25/30	32/40	32/40
Water tank Model	SX-150D	SX-200D	SX-200D	SX-300D
Water tank volume (L)	150	200	200	300
Water tank size (mm)	Φ440*1696	Φ500*1716	Φ500*1716	Φ630*1555
Water tank Packing size (mm)	530*530*1730	610*610*1750	610*610*1750	700*700*1710
Water tank Net Weight / Gross Weight (KG)	55/64	70/79	70/79	90/110

Heat Pump Water Heater / Commercial Type



Heat pump
Commercial hot water



Heat pump
Commercial hot water

Features:

- Modbus: The mainboard has RS 485 communication connection, can communicate via Modbus.
- Full-automatic: Adopt the smart controller, doesn't need manual operation.
- High Efficiency: Adequate heat transfer area ensures the high COP and performance.
- Comfort: High water temperature up to 60°C, large hot water supply.
- Multiple protections: The multiple protective design ensures the system long service life and stable operation, including high pressure protection, low pressure protection, high voltage/current protection, high temperature protection, frosting protection and anti-freeze protection.
- Environmentally friendly: Use the environmentally friendly refrigerant R410A.
- Wide Application: Operation ambient temperature -15°C~43°C, system can be used for hotel, hospital, school, factory and so on.



Product



Application

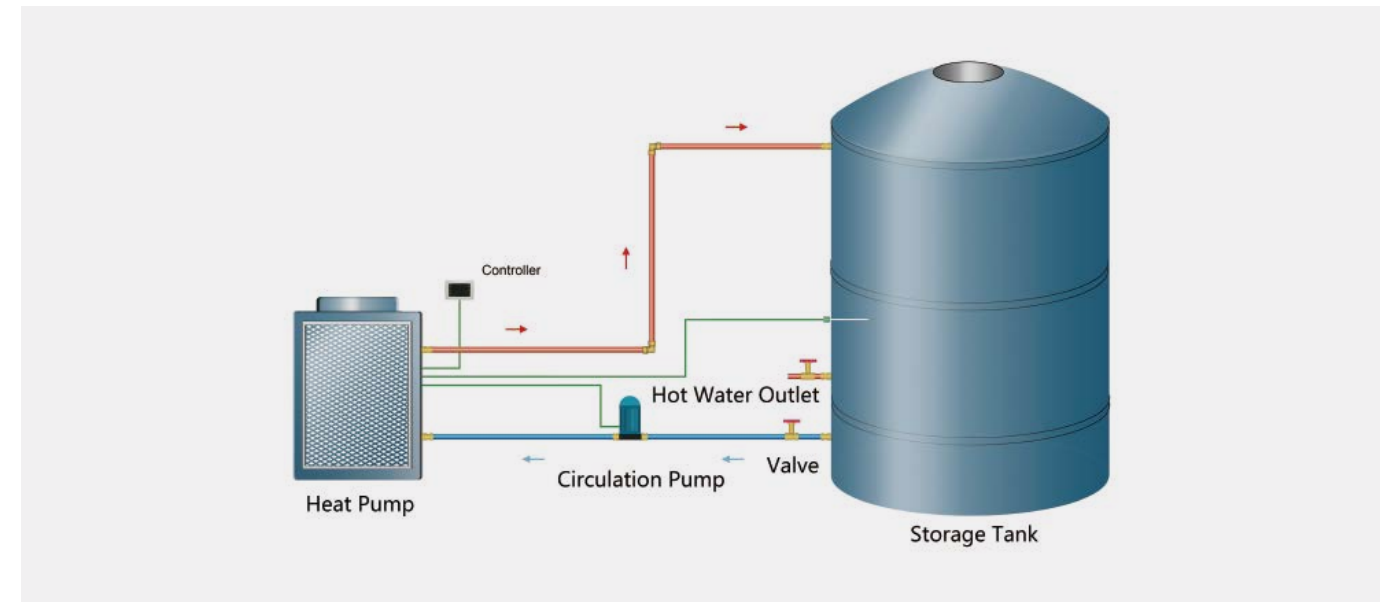



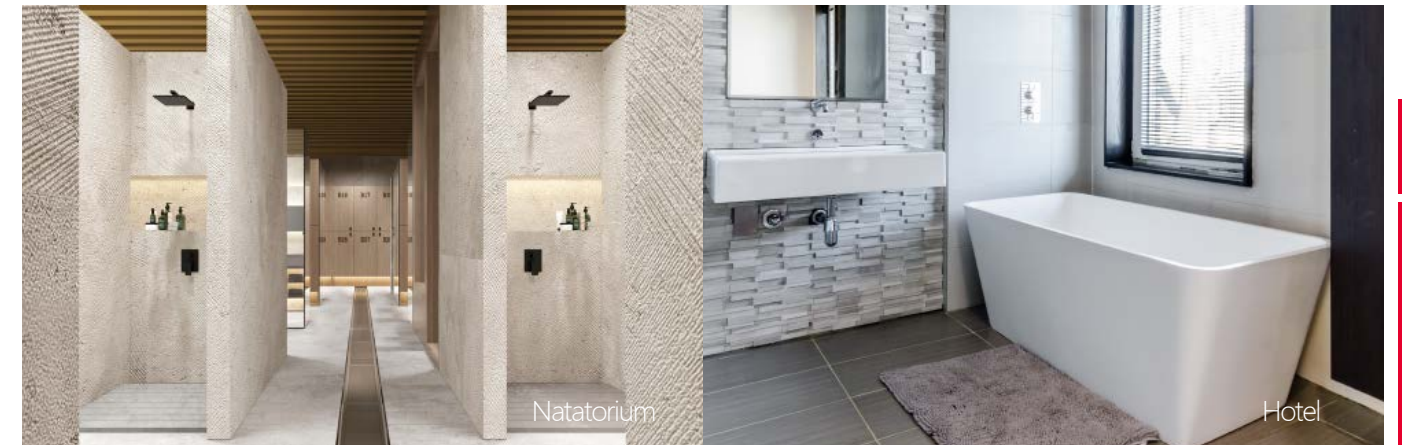

We also provide hot water solutions or heating solution for hotels, schools, hospitals, restaurants !





Heat pump
Commercial hot water

Heat pump
Commercial hot water

Technical Data

Photos				
Model No.	RS-019TA1	RS-022TA1	RS-032TA1	RS-038TA1
Power Supply	380~415V/3/50Hz	380~415V/3/50Hz	380~415V/3/50Hz	380~415V/3/50Hz
Heating Capacity (KW)	18.00	22.00	32.00	38.00
Rated Input Power (KW)	4.20	5.15	7.40	8.75
Rated Current (A)	7.51	9.21	13.51	15.64
COP	4.29	4.27	4.32	4.34
Max Power Input(kW)	7.20	8.70	12.00	13.90
Max Current(A)	12.90	15.60	21.60	24.85
Water Temp. Range (°C)	Default 55, 28~60	Default 55, 28~60	Default 55, 28~60	Default 55, 28~60
Working temp. range(°C)	-15~43	-15~43	-15~43	-15~43
Anti-electric chock class	I	I	I	I
Water proof grade	IPX4	IPX4	IPX4	IPX4
Water flow volume(L/h)	4000	4500	6900	8000
Water Pressure Drop(kPa)	50	50	60	60
Compressor qty.	1	1	2	2
Fan motor qty.	1	1	2	2
Color	Black, Matte surface			
Air Flow Direction	Vertical			
Safeties	LP & HP Cutout, Current & Voltage, Overheat, Temperature, Pressure Protection			
Defrosting	Auto and By manual			
Dimensions(L*W*H)(mm)	752*691*1000	752*691*1000	1410*748*1000	1410*748*1000
Noise(dB(A))	≤57	≤57	≤59	≤59
Net Weight(kg)	155	155	259	259
Water connection(mm)	male 25	male 25	female 32	female 32
Gross Weight(kg)	163	163	269	269
Packing Dimensions(L*W*H)(mm)	792*741*1151	792*741*1151	1460*798*1151	1460*798*1151

Technical Data

Photos					
Model No.	RS-045TA1	RS-076TA1	RS-090TA1	RS-100TA1	RS-200TA1
Power Supply	380~415V/3/50Hz	380~415V/3/50Hz	380~415V/3/50Hz	380~415V/3/50Hz	380~415V/3/50Hz
Heating Capacity (KW)	47.00	76.00	88.00	101.00	192.00
Rated Input Power (KW)	10.82	17.70	21.00	23.38	45.90
Rated Current (A)	19.34	32.00	37.54	41.79	80.30
COP	4.34	4.29	4.19	4.32	4.18
Max Power Input(kW)	16.23	28.50	31.50	33.90	68.85
Max Current(A)	29.01	51.00	56.31	60.60	120.45
Water Temp. Range (°C)	Default 55, 28~60	Default 55, 28~60	Default 55, 28~60	Default 55, 28~60	Default 55, 28~60
Working temp. range(°C)	-15~43	-15~43	-15~43	-25~43	-25 ~ 43
Anti-electric chock class	I	I	I	I	I
Water proof grade	IPX4	IPX4	IPX4	IPX4	IPX4
Water flow volume(L/h)	9500	16000	18000	20000	35000
Water Pressure Drop(kPa)	65	65	65	65	75
Compressor qty.	1	2	1	1	2
Fan motor qty.	1	2	2	2	2
Color	Black, Matte surface				
Air Flow Direction	Vertical				
Safeties	LP & HP Cutout, Current & Voltage, Overheat, Temperature, Pressure Protection				
Defrosting	Auto and By manual				
Dimensions(L*W*H)(mm)	1250*1076*1870	2198*1096*2176	2198*1096*2176	2198*1096*2176	2260*1160*2320
Noise(dB(A))	≤65	≤70	≤70	≤70	≤75
Net Weight(kg)	450	650	700	715	1000
Water connection(mm)	male 40	female 50	female 50	female 50	female 80
Gross Weight(kg)	462	665	725	740	1035
Packing Dimensions(L*W*H)(mm)	1250*1076*1870	2198*1096*2296	2198*1096*2296	2198*1096*2296	2260*1160*2320

Traditional Metal



Features:

- R410A refrigerant, environmental friendly.
- Titanium heat ex-changer, corrosion resistance.
- High pressure protection.
- Defrost automatically.
- With water flow switch.
- MODBUS communication.
- Full automatically operation.
- The heat pump can heat and cool the swimming pool.



Application

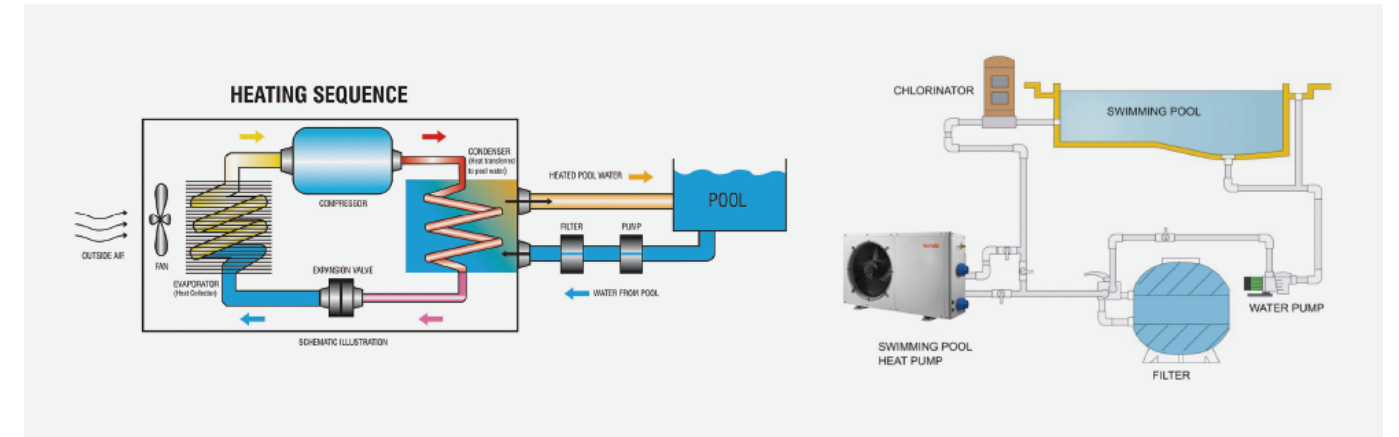

Technical Data

Photos						
Model No.	YC-005TA1	YC-006TA1	YC-008TA1	YC-012TA1	YC-016TA1	YC-030TA1
Power Supply	220~240V/1/50Hz					380~415V/3/50Hz
Heating Capacity at Air 27°C/24°C, Water 27°C in, 29°C out						
Heating Capacity (kW)	5.0	7.2	9.5	13.0	16.1	30.0
Power Input (kW)	0.86	1.24	1.62	2.25	2.75	4.95
COP	5.84	5.81	5.88	5.79	5.85	6.06
Heating Capacity at Air 15°C/12°C, Water 26°C in, 28°C out						
Heating Capacity (kW)	3.6	5.5	7.0	10.0	12.5	23.5
Power Input (kW)	0.73	1.12	1.41	2.05	2.54	4.69
COP	4.94	4.92	4.95	4.88	4.93	5.01
Cooling Capacity at Air 35°C/24°C, Water 29°C in, 27°C out						
Cooling Capacity (kW)	3.2	5.1	6.5	9.2	11.3	20.0
Power Input (kW)	0.94	1.51	1.90	2.69	3.36	5.78
EER	3.41	3.38	3.43	3.42	3.36	3.46
Max Power Input (kW)	1.16	1.68	2.24	3.24	3.72	6.35
Max Current(A)	5.8	8.5	11.3	16.4	18.8	11.4
Refrigerant	R410A	R410A	R410A	R410A	R410A	R410A
Heat Exchanger	Titanium	Titanium	Titanium	Titanium	Titanium	Titanium
Air Flow Direction	Horizotal	Horizotal	Horizotal	Horizotal	Horizotal	Horizotal
Water Flow Volume (m³/h)	2.0	3.0	3.5	5.5	6.0	12.0
Net Dimensions(L*W*H)(mm)	936*385*550	936*385*550	1011*420*614	986*420*798	986*420*798	1003*374*1318
Package Dimensions(L*W*H)(mm)	1055*460*620	1055*460*620	1110*480*670	1115*490*930	1115*490*930	1090*460*1474
Working temperature range (°C)	-15 ~ 43	-15 ~ 43	-15 ~ 43	-15 ~ 43	-15 ~ 43	-15 ~ 43
Noise (dB(A))	48	48	50	52	52	54
Net Weight (kg)	42	46	58	72	85	135
Gross Weight (kg)	48	52	65	87	100	153
Water connection(mm)	50	50	50	50	50	50

Traditional ABS



Features:

- R410A refrigerant, environmental friendly.
- Titanium heat exchanger, corrosion resistance.
- High pressure protection.
- Defrost automatically.
- With water flow switch.
- MODBUS communication.
- Full automatically operation.
- The heat pump can heat and cool the pool water.
- ABS plastic outer shell, corrosion resistance.



Application

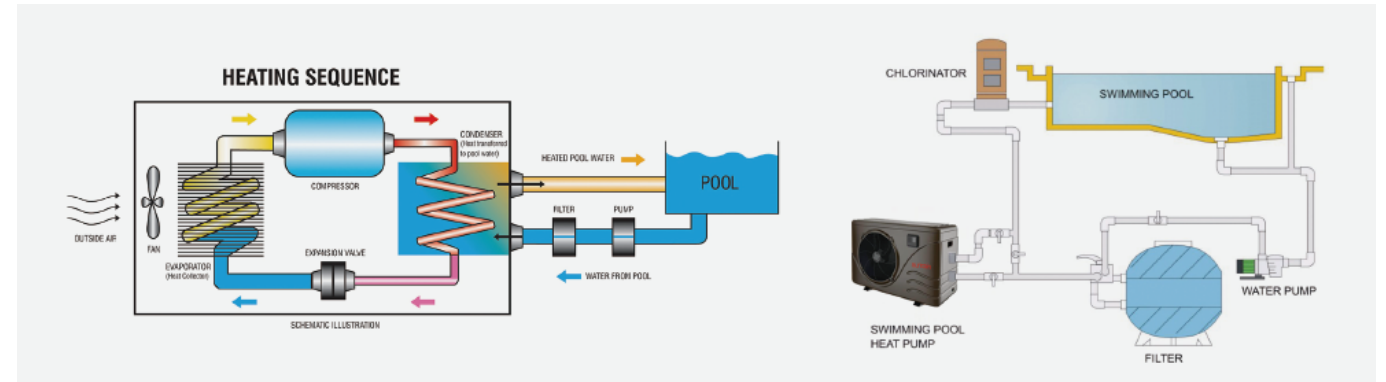

Technical Data

Photos					
Model No.	YC-007TB1	YC-010TB1	YC-012TB1	YC-015TB1	YC-019TB1
Heating Capacity at Air 27°C/24°C, Water 27°C in, 29°C out					
Heating Capacity (kW)	7.2	10.0	12.5	15.0	18.8
Power Input (kW)	1.19	1.63	2.05	2.45	3.13
COP	6.05	6.13	6.10	6.12	6.01
Heating Capacity at Air 15°C/12°C, Water 26°C in, 28°C out					
Heating Capacity (kW)	5.1	7.2	9.5	12.5	15.5
Power Input (kW)	1.00	1.40	1.86	2.44	3.06
COP	5.10	5.14	5.11	5.12	5.06
Cooling Capacity at Air 35°C/24°C, Water 29°C in, 27°C out					
Cooling Capacity (kW)	4.5	6.5	8.5	11.2	14.0
Power Input (kW)	1.30	1.80	2.39	3.22	4.11
EER	3.46	3.62	3.56	3.48	3.41
Power supply	220~240V/1/50Hz				
Max Power Input (kW)	1.8	2.5	3	3.6	4.7
Max Current(A)	9.1	12.6	15.2	18.2	24.5
Refrigerant	R410A				
Heat Exchanger	Titanium				
Air Flow Direction	Horizontal				
Water Flow Volume (m³/h)	3	4	5	6.5	8
Automatic defrosting	by 4 way valve				
Working temperature range (°C)	15 ~ 43				
Noise level (dB(A))	≤ 48	≤ 48	≤ 49	≤ 51	≤ 51
Casing Material	ABS plastic				
Net Dimensions (L*W *H)(mm)	972*430*653	972*430*653	972*430*653	1083*448*704	1083*448*704
Package Dimensions (L*W*H)(mm)	1022*460*788	1022*460*788	1022*460*788	1130*460*830	1130*460*830
Net Weight (kg)	46	51	58	72	85
Gross Weight (kg)	59	65	73	88	102

Mini Heater



Heat pump
Swimming pool

Heat pump
Swimming pool

Advantages

- ★ R32 new refrigerant.
- ★ True Mini. 900+ Pcs for 40HC.
- ★ COP up to 5.2
- ★ Removable 38/32mm connection.
- ★ Water flow switch available.
- ★ 3/4/5kW available.



Technical Data

Photos			
Model No.	YC-003TB1	YC-004TB1	YC-005TB1
* Heating Capacity at Air 26°C, Humidity 80%, Water 26°C in, 28°C out			
Heating Capacity (kW)	3.00	4.00	5.00
Power Input (kW)	0.58	0.77	0.97
COP	5.17	5.20	5.17
* Heating Capacity at Air 15°C, Humidity 70%, Water 26°C in, 28°C out			
Heating Capacity (kW)	2.30	2.90	3.85
Power Input (kW)	0.55	0.69	0.92
COP	4.18	4.20	4.18
* General data			
Power supply	220~240V/1/50Hz		
Max Power Input (kW)	0.70	0.90	1.14
Max Current (A)	3.2	4.8	5.8
Water Flow Volume (m³/h)	1.5	2.0	2.5
Advised pool size m3	0~10	5~16	8~20
Refrigerant	R32		
Water connection (mm)	32 or 38		
Heat Exchanger	Titanium		
Air Flow Direction	Horizontal		
Working temp. range (°C)	12~43		
Casing Material	ABS+Metal		
Noise level dB(A)	45	46	48
Net Weight (kg)	18	22	26
Gross Weight (kg)	20	24	30
Net Dimensions (mm)	380*290*370		420*365*440
Package Dimensions (mm)	440*355*400		480*435*490

Features:



Inver-Wave



Features:

- Full inverter, higher COP, better performance.
- R32 refrigerant, environmental friendly.
- Titanium heat exchanger, corrosion resistance .
- Intelligent controller.
- WIFI function included.
- MODBUS communication.
- Heating, cooling & Auto function included.



Application

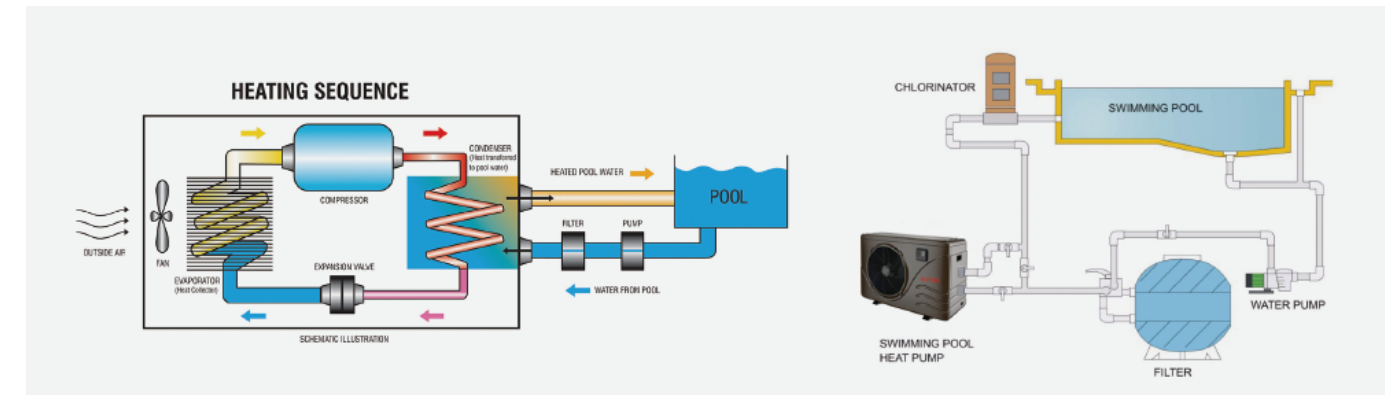

Technical Data

Photos						
Model No.	BYC-007TB1	BYC-010TB1	BYC-013TB1	BYC-017TB1	BYC-021TB1	BYC-025TB1
Heating Capacity at Air 26°C, Humidity 80%, Water 26°C in, 28°C out						
Heating Capacity (kW)	7.8~1.8	9.8~2.3	12.6~3.0	16.5~3.8	20.5~4.7	25.5~6.4
Power Input (kW)	1.15~0.11	1.42~0.14	1.83~0.19	2.39~0.24	2.97~0.30	3.70~0.40
COP	15.8~6.8	15.8~6.9	15.9~6.9	15.9~6.9	15.8~6.9	15.9~6.9
Heating Capacity at Air 15°C, Humidity 70%, Water 26°C in, 28°C out						
Heating Capacity (kW)	6.2~1.4	7.7~1.8	9.8~2.3	12.2~2.7	15.1~3.5	20.2~4.9
Power Input (kW)	1.27~0.18	1.57~0.24	1.99~0.30	2.49~0.36	3.08~0.47	4.12~0.64
COP	7.6~4.9	7.6~4.9	7.6~4.9	7.6~4.9	7.6~4.9	7.6~4.9
Cooling Capacity at Air 35°C, Water 29°C in, 27°C out						
Cooling Capacity (kW)	4.3~1.1	5.5~1.4	7.3~1.7	9.1~2.2	11.2~2.5	14.5~3.2
Power Input (kW)	1.13~0.16	1.45~0.21	1.87~0.25	2.33~0.33	2.95~0.37	3.72~0.48
EER	6.7~3.8	6.7~3.8	6.7~3.9	6.7~3.9	6.7~3.8	6.7~3.9
Power supply	220~240V / 1/ 50 Hz					
Max Power Input (kW)	1.3	1.6	2	2.5	3.1	4.2
Max Current (A)	5.9	7.3	9.1	11.4	14.1	19
Refrigerant	R32					
Heat Exchanger	Titanium					
Air Flow Direction	Horizontal					
Water Flow Volume (m³/h)	2.5	3.5	4.5	5.5	6.5	9
Automatic defrosting	by 4 way valve					
Working temperature range (°C)	-15~43	-15~43	-15~43	-15~43	-15~43	-15~43
Noise level 1m dB(A)	39~49	40~49	42~50	42~50	44~51	45~53
Noise level 10m dB(A)	20~29	20~32	22~33	23~35	25~36	27~38
Casing Material	ABS plastic					
Net Dimensions (L*W *H) (mm)	850*360*590			972*430*653		1083*448*704
Package Dimensions (L*W*H)(mm)	920*440*770			1022*460*788		1130*460*830
Net Weight (kg)	44	46	55	56	60	92
Gross Weight (kg)	55	57	66	67	72	105

Heat pump Swimming pool

Heat pump Swimming pool

Inver-Spark



Features:

- Full Inverter with R32 refrigerant.
- High-end Mitsubishi compressor.
- DC Inverter fan motor.
- High efficiency COP up to 16.
- Quiet running experience.
- Built in WiFi function.
- Hot gas defrosting.
- Precise gas control with EEV.



Stable silent operation (1 Meter Distance)



Convenient experience

Intelligent Inverter tech will keep the constant water temperature automatically, much more convenient swimming experience than ON/OFF system.

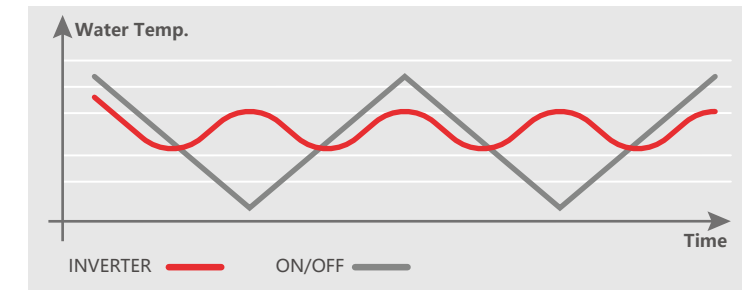

Eco-friendly R32:

- Much lower influence to Global warming.
- Save your cost of F-gas quota by 2/3 than R410A.



Technical Data

Photos									
Model No.	BYC-007TD1	BYC-010TD1	BYC-013TD1	BYC-017TD1	BYC-021TD1	BYC-030TD1	BYC-035TD1	BYC-030TD3	BYC-035TD3
* Heating Capacity at Air 26°C, Humidity 80%, Water 26°C in, 28°C out									
Heating Capacity (kW)	7.6~1.7	9.5~2.3	13~3.0	17~3.8	21~4.8	28~6.8	35~8.8	28~6.8	35~8.8
Power Input (kW)	1.12~0.11	1.40~0.15	1.91~0.19	2.5~0.24	3.09~0.30	4.12~0.43	5.15~0.56	3.97~0.43	5.15~0.56
COP	15.8~6.8	15.8~6.8	16~6.8	15.8~6.8	15.8~6.8	15.8~6.8	15.8~6.8	15.8~6.8	15.8~6.8
* Heating Capacity at Air 15°C, Humidity 70%, Water 26°C in, 28°C out									
Heating Capacity (kW)	6.1~1.4	7.6~1.9	9.8~2.3	13.5~3	16.5~3.8	23~5.5	25.5~6.4	23~5.5	25.5~6.4
Power Input (kW)	1.24~0.18	1.55~0.25	1.96~0.30	2.76~0.39	3.37~0.5	4.7~0.72	5.2~0.84	4.7~0.72	5.2~0.84
COP	7.6~4.9	7.6~4.9	7.6~5	7.6~4.9	7.6~4.9	7.6~4.9	7.6~4.9	7.6~4.9	7.6~4.9
* Cooling Capacity at Air 35°C, Water 29°C in, 27°C out									
Cooling Capacity (kW)	4.2~1.0	5.3~1.3	7.2~1.7	9.4~2.1	11.6~2.7	14.9~3.8	19.3~4.9	14.9~3.8	19.3~4.9
Power Input (kW)	1.11~0.15	1.4~0.19	1.89~0.25	2.47~0.31	3.05~0.4	3.92~0.57	5.08~0.73	3.92~0.57	5.08~0.73
EER	6.6~3.8	6.7~3.8	6.7~3.8	6.7~3.8	6.7~3.8	6.7~3.8	6.7~3.8	6.7~3.8	6.7~3.8
* General data									
Power supply	220~240V/1/50Hz							380~415V/3/50Hz	
Max Power Input (kW)	1.55	1.78	2.2	2.6	3.2	4.45	4.76	6.43	6.93
Max Current (A)	7.3	8.3	10.2	12	14.7	20.4	30	7.9	11.3
Water Flow Volume (m³/h)	2.5	3.5	4.5	5.5	6.5	9	12	9	12
Refrigerant	R32								
Heat Exchanger	Titanium								
Air Flow Direction	Horizontal								
Automatic defrosting	by 4 way valve								
Working temp. range (°C)	-15~43								
Casing Material	ABS								
Water Proof Level	IPX4								
Noise level 1m dB(A)	39~49	40~52	42~53	43~55	45~56	47~58	49~59	47~58	49~59
Noise level 10m dB(A)	20~29	20~32	22~33	23~35	25~36	27~38	29~39	27~38	29~39
Net Weight (kg)	42	43	53	54	58	88	98	88	98
Gross Weight (kg)	53	54	64	65	69	99	110	99	110
Net Dimensions (mm)	864*349*592			925*364*642			1084*399*737		
Package Dimensions (mm)	930*400*640			990*435*760			1146*460*862		

Inver-Premium

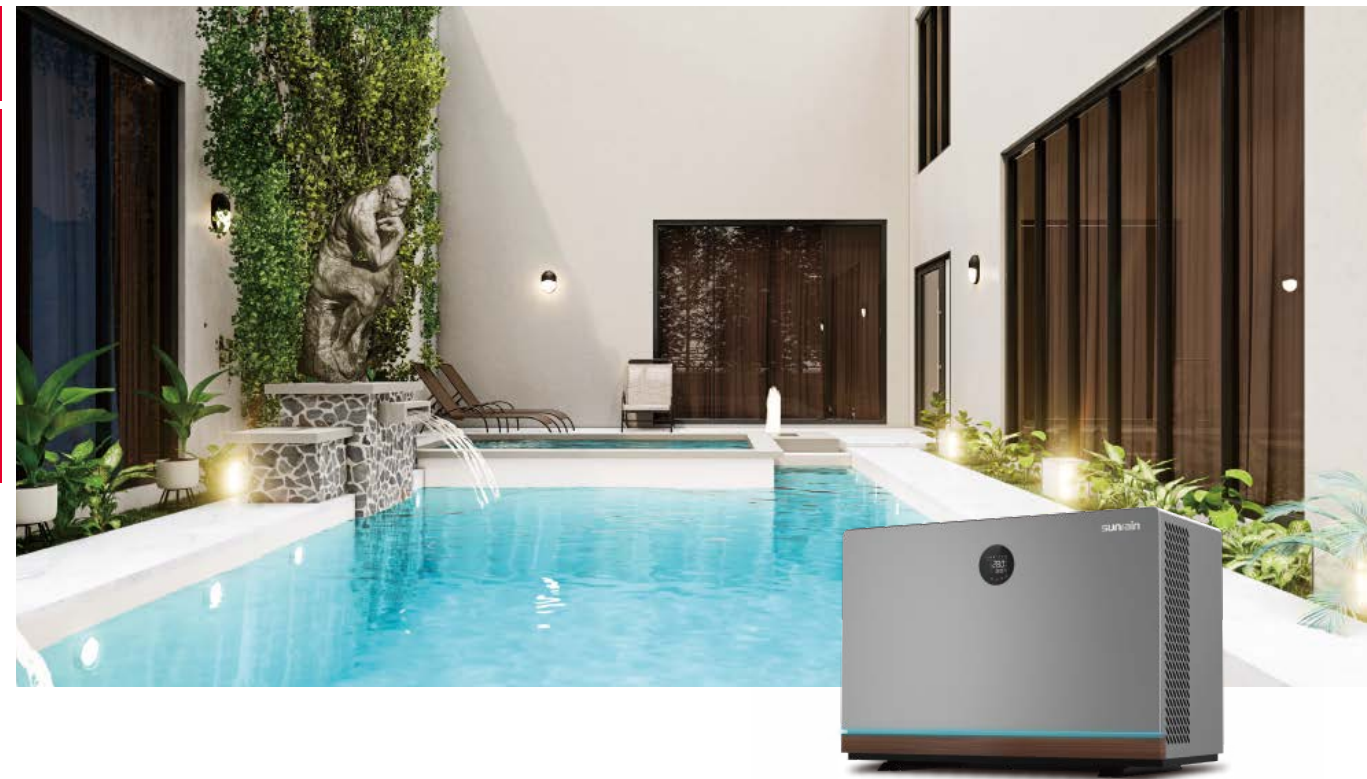

Features:



Ultra quiet operation (10 Meters Distance)



Technical Data

Photos								
Model No.	BYC-007TH1	BYC-010TH1	BYC-013TH1	BYC-017TH1	BYC-021TH1	BYC-025TH1	BYC-025TH3	
* Heating Capacity at Air 26°C, Humidity 80%, Water 26°C in, 28°C out								
Heating Capacity (kW)	7.0~1.7	9~2.3	12.5~3.0	16.5~3.8	20.5~4.8	25~6.8	25~6.8	
Power Input (kW)	1.04~0.12	1.34~0.16	1.84~0.21	2.46~0.25	3.06~0.32	3.73~0.44	3.73~0.44	
COP	14.5~6.7	14.3~6.7	14.5~6.8	15~6.7	15~6.7	15.5~6.7	15.5~6.7	
* Heating Capacity at Air 15°C, Humidity 70%, Water 26°C in, 28°C out								
Heating Capacity (kW)	5.3~1.3	6.8~1.7	9.3~2.2	12.3~2.8	15.0~3.5	19.0~4.9	19.0~4.9	
Power Input (kW)	1.06~0.17	1.39~0.23	1.86~0.29	2.51~0.37	3.06~0.47	3.88~0.65	3.88~0.65	
COP	7.5~5.0	7.5~4.9	7.5~5.0	7.5~4.9	7.5~4.9	7.5~4.9	7.5~4.9	
* Cooling Capacity at Air 35°C, Water 29°C in, 27°C out								
Cooling Capacity (kW)	3.7~1.0	4.9~1.4	6.5~1.8	8.2~2.3	10.2~2.8	12.5~3.8	12.5~3.8	
Power Input (kW)	1.0~0.15	1.32~0.21	1.76~0.27	2.22~0.35	2.76~0.42	3.38~0.58	3.38~0.58	
EER	6.6~3.7	6.6~3.7	6.6~3.7	6.6~3.7	6.6~3.7	6.6~3.7	6.6~3.7	
* General data								
Power supply	220~240V/1/50Hz						380~415V/3/50Hz	
Max Power Input (kW)	1.4	1.7	2.1	2.5	3.1	4.3	4.3	
Max Current (A)	6.6	8.1	10	11.9	14.7	20.5	7.2	
Water Flow Volume (m³/h)	2.5	3.5	4.5	5.5	6.5	9	9	
Refrigerant	R32							
Heat Exchanger	Titanium							
Air Flow Direction	Horizontal							
Automatic defrosting	by 4 way valve							
Working temp. range (°C)	-15~43							
Casing Material	Aluminum alloy & Metal							
Water Proof Level	IPX4							
Noise level 1m dB(A)	37~46	38~47	40~49	41~51	41~52	42~52	42~52	
Noise level 10m dB(A)	18~27	19~28	20~29	21~31	21~32	23~33	23~33	
Net Weight (kg)	46	48	55	63	68	88	88	
Gross Weight (kg)	56	58	65	73	78	98	98	
Net Dimensions (mm)	870*420*640			1050*420*690		1050*420*900		
Package Dimensions (mm)	930*470*760			1110*470*810		1110*470*1020		

Inver-Nova

Heat pump
Swimming pool



Features:

- Full inverter, higher COP, better performance.
- R32 refrigerant, environmental friendly.
- Titanium heat exchanger, corrosion resistance .
- Intelligent controller.
- WIFI function included.
- MODBUS communication.
- heating, cooling & Auto function included.



Application

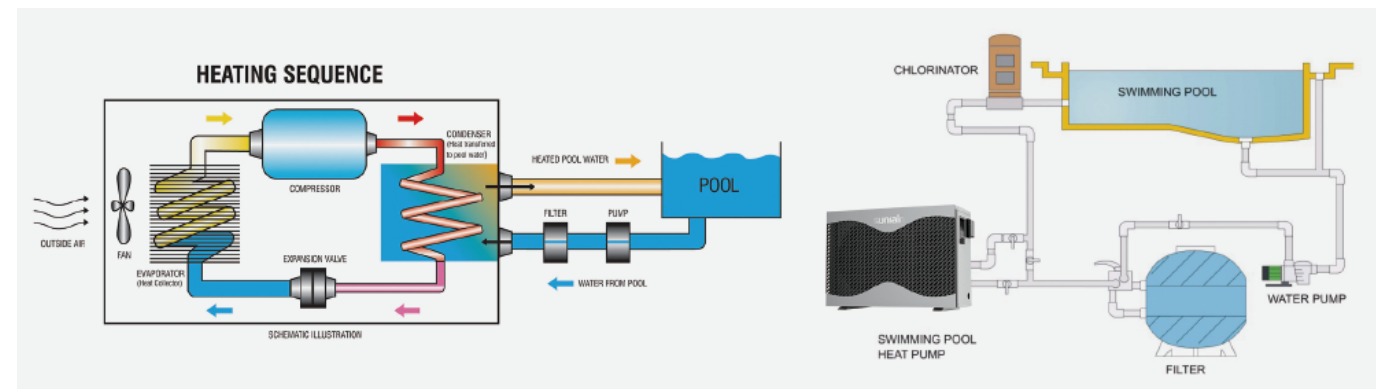

Heat pump
Swimming pool

Technical Data

Photos								
Model No.	BYC-007TG1	BYC-010TG1	BYC-013TG1	BYC-017TG1	BYC-021TG1	BYC-030TG1	BYC-030TG3	
Heating Capacity at Air 26°C, Humidity 80%, Water 26°C in, 28°C out								
Heating Capacity (kW)	7.7~1.8	10~2.3	13.2~3.1	17.1~3.9	21~4.9	28.2~6.9	28.4~7.1	
Power Input (kW)	1.13~0.11	1.45~0.15	1.91~0.19	2.51~0.25	3.09~0.31	4.15~0.44	4.18~0.45	
COP	15.8~6.8	15.8~6.9	16~6.9	15.9~6.8	15.8~6.8	15.8~6.8	15.8~6.8	
Heating Capacity at Air 15°C, Humidity 70%, Water 26°C in, 28°C out								
Heating Capacity (kW)	5.7~1.3	7.9~1.8	10.1~2.3	12.8~2.9	15.9~3.6	22.1~5.0	22.1~5.0	
Power Input (kW)	1.16~0.17	1.58~0.23	2.03~0.30	2.57~0.38	3.20~0.47	4.43~0.65	4.44~0.65	
COP	7.6~4.9	7.6~4.9	7.6~4.9	7.6~4.9	7.6~4.9	7.6~4.9	7.6~4.9	
Cooling Capacity at Air 35°C, Water 29°C in, 27°C out								
Cooling Capacity (kW)	4.2~1.1	5.9~1.5	7.2~1.8	9.4~2.3	11.5~2.9	15.8~3.9	15.9~3.9	
Power Input (kW)	1.13~0.17	1.57~0.22	1.89~0.26	2.51~0.34	3.16~0.43	4.19~0.56	4.18~0.56	
EER	6.6~3.7	6.7~3.7	6.9~3.8	6.9~3.8	6.9~3.7	6.9~3.8	6.9~3.8	
Power supply	220~240V / 1/ 50 Hz						380~415V / 3/ 50 Hz	
Max Power Input (kW)	1.2	1.6	2.1	2.6	3.2	4.4	4.5	
Max Current(A)	5.5	7.3	9.6	11.9	14.5	20	8.4	
Refrigerant	R32	R32	R32	R32	R32	R32	R32	
Heat Exchanger	Titanium	Titanium	Titanium	Titanium	Titanium	Titanium	Titanium	
Air Flow Direction	Horizontal	Horizontal	Horizontal	Horizontal	Horizontal	Horizontal	Horizontal	
Water Flow Volume (m³/h)	2.5	3.5	4.5	5.5	6.5	9	9	
Automatic defrosting	by 4 way valve	by 4 way valve	by 4 way valve	by 4 way valve	by 4 way valve	by 4 way valve	by 4 way valve	
Working temp. range (°C)	-15~43	-15~43	-15~43	-15~43	-15~43	-15~43	-15~43	
Noise level 1m dB(A)	38~48	39~51	41~52	42~54	44~55	46~57	46~57	
Noise level 10m dB(A)	19~28	19~31	21~32	22~34	24~35	26~37	26~37	
Net Dimensions (mm) (L*W*H)	821*405*587		850*405*637			1036*448*739		
Package Dimensions (mm) (L*W*H)	883*435*722		912*435*777			1098*488*879		
Net Weight(kg)	42	44	53	56	60	88	88	
Gross Weight(kg)	53	55	64	67	71	99	99	
Water Proof Level	IPX4	IPX4	IPX4	IPX4	IPX4	IPX4	IPX4	

Inver-TOP

Heat pump
Swimming pool



Features:

- Fully Inverter with R32 refrigerant.
- High-end Mitsubishi compressor.
- Titanium heat exchanger.
- Premium touch screen display.
- Heating, Cooling & Automatic mode.
- Built-in WiFi function.
- Top discharge air outlet.
- Multi-protection for safe operation.



Save space

With the vertical exhaust design, Inver-Top can save much installation space in your garden.



Built-in WiFi function

Control your pool heat pump via the App on your smart phone, at Anywhere & Anytime.



Heat pump
Swimming pool

Technical Data

Photos									
Model No.	BYC-007TV1	BYC-010TV1	BYC-013TV1	BYC-017TV1	BYC-021TV1	BYC-030TV1	BYC-035TV1	BYC-030TV3	BYC-035TV3
* Heating Capacity at Air 26°C, Humidity 80%, Water 26°C in, 28°C out									
Heating Capacity (kW)	7.2~1.7	9.2~2.3	12.5~3.0	16.5~3.8	21~4.8	28~6.8	35~8.8	28~6.8	35~8.8
Power Input (kW)	1.06~0.11	1.35~0.15	1.84~0.19	2.43~0.24	3.09~0.30	4.12~0.43	5.15~0.56	3.97~0.43	5.15~0.56
COP	15.8~6.8	15.8~6.8	16~6.8	15.8~6.8	15.8~6.8	15.8~6.8	15.8~6.8	15.8~6.8	15.8~6.8
* Heating Capacity at Air 15°C, Humidity 70%, Water 26°C in, 28°C out									
Heating Capacity (kW)	5.9~1.4	7.4~1.9	9.5~2.3	13.1~3	16.5~3.8	23~5.5	25.5~6.4	23~5.5	25.5~6.4
Power Input (kW)	1.2~0.18	1.51~0.25	1.9~0.30	2.67~0.39	3.37~0.5	4.7~0.72	5.2~0.84	4.7~0.72	5.2~0.84
COP	7.6~4.9	7.6~4.9	7.6~5	7.6~4.9	7.6~4.9	7.6~4.9	7.6~4.9	7.6~4.9	7.6~4.9
* Cooling Capacity at Air 35°C, Water 29°C in, 27°C out									
Cooling Capacity (kW)	4.2~1.0	5.3~1.3	7.2~1.7	9.4~2.1	11.6~2.7	14.9~3.8	19.3~4.9	14.9~3.8	19.3~4.9
Power Input (kW)	1.11~0.15	1.4~0.19	1.89~0.25	2.47~0.31	3.05~0.4	3.92~0.57	5.08~0.73	3.92~0.57	5.08~0.73
EER	6.6~3.8	6.7~3.8	6.7~3.8	6.7~3.8	6.7~3.8	6.7~3.8	6.7~3.8	6.7~3.8	6.7~3.8
* General data									
Power supply	220~240V/1/50Hz							380~415V/3/50Hz	
Max Power Input (kW)	1.45	1.75	2.2	2.5	3.2	4.45	6.43	4.76	6.93
Max Current (A)	7.1	8.3	10.2	11.9	14.7	20.4	30	7.9	11.3
Water Flow Volume (m³/h)	2.5	3.5	4.5	5.5	6.5	9	12	9	12
Refrigerant	R32								
Heat Exchanger	Titanium								
Air Flow Direction	Vertical								
Automatic defrosting	by 4 way valve								
Working temp. range (°C)	-15~43								
Casing Material	ABS								
Water Proof Level	IPX4								
Noise level 1m dB(A)	39~49	40~52	42~53	43~55	45~56	47~58	49~59	47~58	49~59
Noise level 10m dB(A)	20~29	20~32	22~33	23~35	25~36	27~38	29~39	27~38	29~39
Net Weight (kg)	44	46	55	57	61	86	92	86	92
Gross Weight (kg)	55	57	68	70	72	96	104	96	104
Net Dimensions (mm)	530*530*640			650*650*770			715*715*955		
Package Dimensions (mm)	560*600*780			680*720*910			765*785*1080		

Commercial Max

Heat pump
Swimming pool



Features:

- R410A refrigerant, environmental friendly.
- Higher water temperature output up to 40°C.
- Titanium heat exchanger, corrosion resistance.
- High pressure protection.
- Defrost automatically.
- With MODBUS communication.
- Full automatically operation.







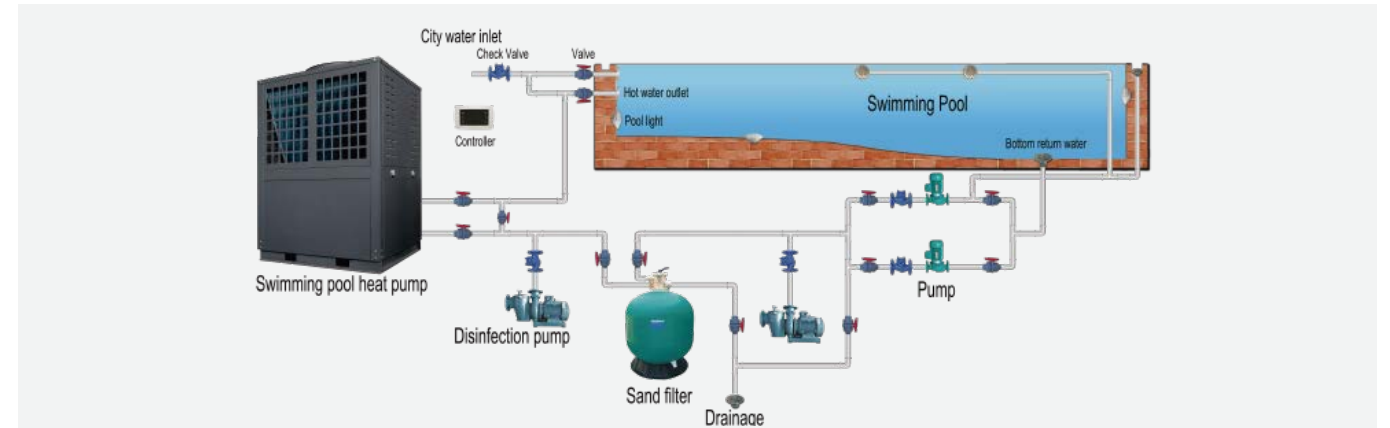

MODBUS

Application



Heat pump
Swimming pool

Technical Data

Photos						
Model No.	YC-025TA1	YC-050TA1	YC-075TA1	YC-120TA1	YC-170TA1	YC-220TA1
Power Supply	380~415V/3/50Hz	380~415V/3/50Hz	380~415V/3/50Hz	380~415V/3/50Hz	380~415V/3/50Hz	380~415V/3/50Hz
Heating Capacity at Air 27°C/24°C, Water 27°C in, 29°C out						
Heating Capacity (kW)	25	50	70	120	170	220
Power Input (kW)	4.2	8.4	11.7	20.1	28.6	37.6
COP	5.91	5.95	5.96	5.98	5.95	5.85
Heating Capacity at Air 15°C/12°C, Water 26°C in, 28°C out						
Heating Capacity (kW)	20	42	60	100	140	185
Power Input (kW)	4.1	8.6	12.3	20.4	28.9	38.6
COP	4.86	4.88	4.89	4.89	4.85	4.79
Cooling Capacity at Air 35°C/24°C, Water 29°C in, 27°C out						
Cooling Capacity (kW)	18	36	55	85	120	160
Power Input (kW)	5.3	10.5	15.9	24.6	35.2	47.6
EER	3.39	3.42	3.45	3.45	3.41	3.36
Max Power Input (kW)	6.9	13.2	20.1	29.1	48.5	67.2
Max Current(A)	12.3	23.5	35.9	52.2	87.0	121.1
Refrigerant	R410a	R410A	R410A	R410A	R410A	R410A
Heat Exchanger	Titanium	Titanium	Titanium	Titanium	Titanium	Titanium
Expansion Valve	Electronic	Electronic	Electronic	Electronic	Electronic	Electronic
Air Flow Direction	Vertical	Vertical	Vertical	Vertical	Vertical	Vertical
Water Flow Volume (m³/h)	10	20	30	50	70	85
Net Dimensions(L*W*H) (mm)	765*691*1055	1416*752*1055	1250*1076*1870	2150*1078*2258	2150*1078*2258	2150*1078*2258
Working temperature range (°C)	-15 ~ 43	-15 ~ 43	-15 ~ 43	-15 ~ 43	-15 ~ 43	-15 ~ 43
Noise (dB(A))	≤57	≤59	≤62	≤66	≤66	≤70
Net Weight (kg)	120	250	450	760	900	1200
Water connection(mm)	50	65	65	75	90	110

Inver-Max

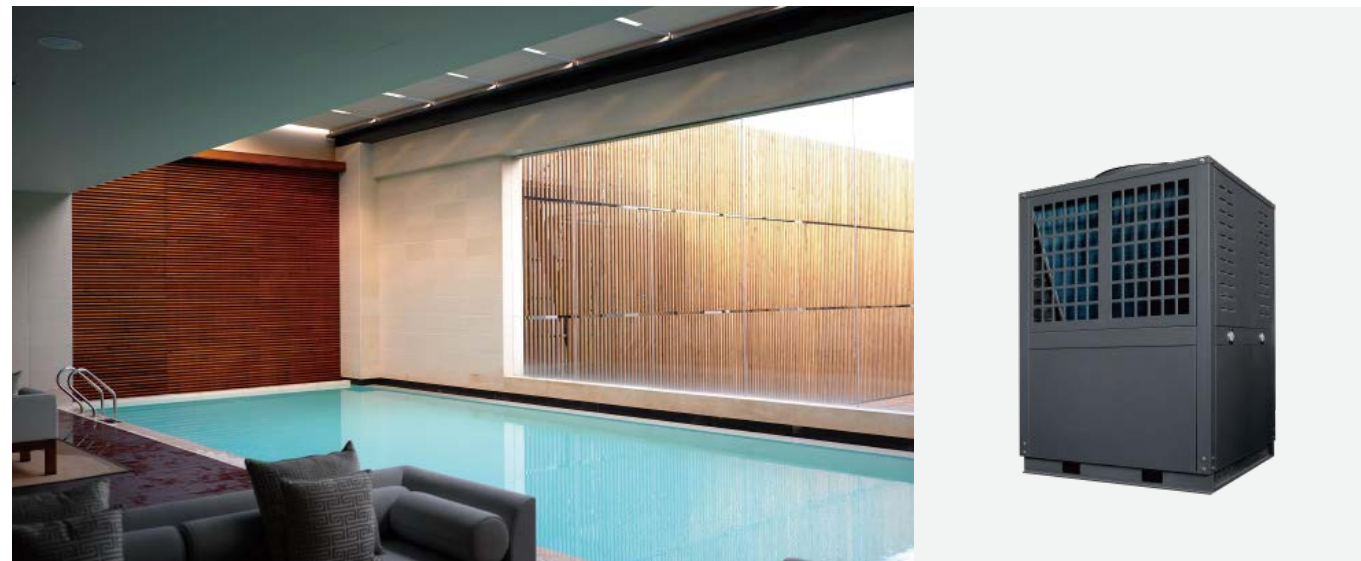

Features:



- Full inverter, higher COP, better performance.
- R32 refrigerant, environmental friendly.
- Titanium heat exchanger, corrosion resistance.
- Touch-screen controller, easy operation.
- WIFI function included.
- MODBUS communication.
- Heating, cooling & Auto function included.

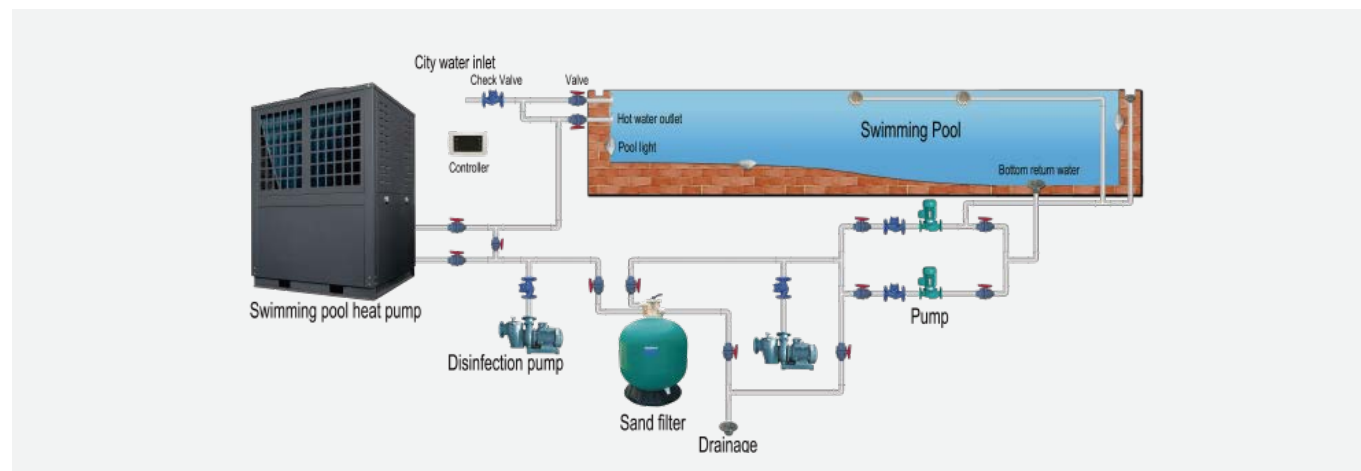

Application



Technical Data

Photos			
Model No.	BYC-070TA1	BYC-103TA1	BYC-136TA1
Power Supply	380~415V/3/50Hz	380~415V/3/50Hz	380~415V/3/50Hz
Heating Capacity at Air 26°C, Water 26°C, Humidity 80%			
Heating Capacity (kW)	70 ~ 16.5	103 ~ 24.8	136 ~ 32.4
Power Input (kW)	10.03 ~ 1.02	14.80 ~ 1.54	19.46 ~ 2.01
COP	16.11 ~ 6.98	16.09 ~ 6.96	16.15 ~ 6.99
Heating Capacity at Air 15°C, Water 26°C, Humidity 70%			
Heating Capacity (kW)	51 ~ 12.1	76 ~ 18.3	101 ~ 23.9
Power Input (kW)	10.24 ~ 1.6	15.29 ~ 2.42	20.24 ~ 3.15
COP	7.56 ~ 4.98	7.55 ~ 4.97	7.59 ~ 4.99
Cooling Capacity at Air 35°C, Water 27°C			
Cooling Capacity (kW)	38 ~ 9.1	58 ~ 14.1	76 ~ 18.5
Power Input (kW)	10.41 ~ 1.36	15.89 ~ 2.11	20.65 ~ 2.74
EER	6.69 ~ 3.65	6.68 ~ 3.65	6.74 ~ 3.68
Rated Power Input (kW)	10.0	15.0	20.0
Rated Current(A)	18	27	36
Max Power Input (kW)	15.0	22.0	30.0
Max Current(A)	26	38	54
Refrigerant	R32	R32	R32
Compressor Type	Mitsubishi inverter	Mitsubishi inverter	Mitsubishi inverter
Heat Exchanger	Titanium	Titanium	Titanium
Expansion Valve	Electronic EEV	Electronic EEV	Electronic EEV
Air Flow Direction	Vertical	Vertical	Vertical
Water Flow Volume (m³/h)	20	30	40
Net Dimensions(L*W*H) (mm)	1416*752*1055	1250*1080*1870	2150*1080*2180
Package Dimensions(L*W*H)	1580*880*1150	1300*1100*1950	2230*1120*2200
Working temperature range (°C)	-15 ~ 43	-15 ~ 43	-15 ~ 43
Heating temperature range (°C)	15 ~ 40	15 ~ 40	15 ~ 40
Cooling temperature range (°C)	8~28	8~28	8~28
Noise (dB(A))	≤59	≤62	≤65
Net Weight (kg)	280	420	750
Gross Weight (kg)	320	460	810
Water connection(mm)	63	63	75

Heat pump
Swimming pool

Heat pump
Swimming pool

Monoblock Heat Pump / Heating & Cooling&DHW / DC Inverter / Residential Type



Heat pump
Heating and cooling



Features:

- Energy class: A+++
- Heating+Cooling+DHW
- Full DC inverter Panasonic compressor and fan motor
- -30°C inverter EVI
- WIFI smart control
- R32 refrigerant, environmental friendly
- Outlet water temperature up to 60°C



Application

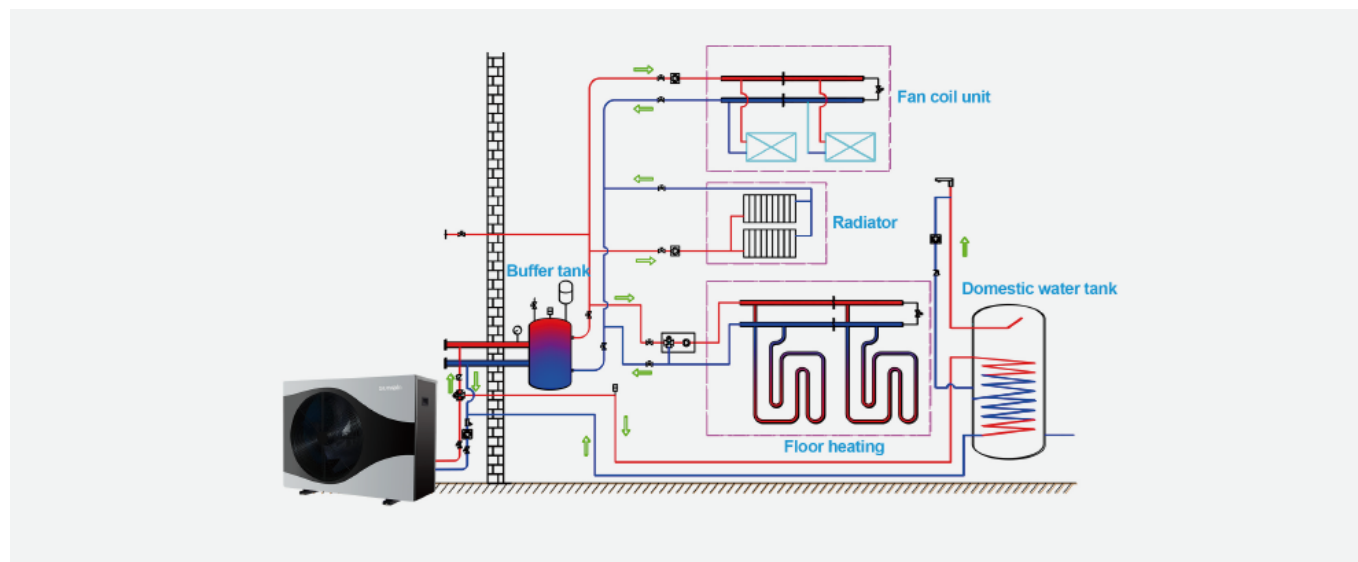

Technical Data

Photos										
Model		BLN-006TB1	BLN-010TB1	BLN-010TB3	BLN-014TB1	BLN-014TB3	BLN-018TB1	BLN-018TB3	BLN-024TB3	
Power supply	V/Ph/Hz	220~240/1/50	220~240/1/50	380~415/3/50	220~240/1/50	380~415/3/50	220~240/1/50	380~415/3/50	380~415/3/50	
Nominal Heating (Max) (A7/6°C,W30/35°C)	Heating Capacity	kW	6.46(2.50-8.30)	10.58(4.20-12.20)	10.58(4.20-12.20)	14.45(5.30-16.50)	14.45(5.30-16.60)	18.77(6.20-20.50)	18.77(6.20-20.50)	24.33 (6.50-26.10)
	Power Input	kW	1.31	2.29	2.29	3.06	3.06	3.99	3.99	5.10
	COP	W/W	4.93	4.62	4.62	4.72	4.72	4.70	4.70	4.77
Nominal Heating (Max) (A7/6°C,W47/55°C)	Heating Capacity	kW	5.92	9.47	9.47	13.89	13.89	16.90	16.90	24.29
	Power Input	kW	1.85	3.09	3.09	4.47	4.47	5.47	5.47	7.93
	COP	W/W	3.21	3.06	3.06	3.11	3.11	3.09	3.09	3.06
Nominal Cooling (Max) (A35/24°C,W12/7°C)	Cooling Capacity	kW	5.66	8.34	8.34	13.24	13.24	15.88	15.88	20.89
	Power Input	kW	1.74	2.66	2.66	4.12	4.12	4.99	4.99	6.70
	EER	W/W	3.25	3.14	3.14	3.21	3.21	3.18	3.18	3.12
ERP Level (Outlet water temp. at 35°C)	/	A+++	A+++	A+++	A+++	A+++	A+++	A+++	A+++	
ERP Level (Outlet water temp. at 55°C)	/	A++	A++	A++	A++	A++	A++	A++	A++	
Rated input power	kW	2.71	3.83	3.83	5.97	5.97	7.24	7.24	9.38	
Rated input current	A	12.00	17.00	6.5	26.50	10.50	35.50	13.20	17.30	
Refrigerant / Weight	/	R32	R32	R32	R32	R32	R32	R32	R32	
Rated water flow	m3/h	1.10	1.75	1.75	2.50	2.50	3.20	3.20	4.20	
Fan quantity	/	1	1	1	1	1	2	2	2	
Fan motor type	/	DC inverter								
Compressor	/	Panasonic / DC inverter / Rotary / EVI								
Circulating pump	/	Inverter type / Built-in								
IP Class	/	IPX4								
Sound pressure at 1m distance	dB(A)	50	51	51	52	52	54	54	55	
Max outlet water temperature	°C	60	60	60	60	60	60	60	60	
Water piping connections	/	DN 25 (1")	DN 25 (1")	DN 25 (1")	DN 32 (1-1/4")	DN 32 (1-1/4")	DN 40 (1.5")	DN 40 (1.5")	DN 40 (1.5")	
Pressure drop at rating water flow	kPa	25	27	27	30	30	32	32	32	
Operating temperature range(Heating mode)	°C	-30~45								
Operating temperature range(Cooling mode)	°C	16~45								
Unpacked Dimensions (L×D×H)	mm	1110*445*850	1110*445*850	1110*445*850	1110*475*850	1110*475*850	1050*420*1250	1050*420*1250	1050*420*1250	
Packed Dimensions (L×D×H)	mm	1160*530*1010	1160*530*1010	1160*530*1010	1160*565*1010	1160*565*1010	1100*480*1400	1100*480*1400	1100*480*1400	
UnPacked Weight	kg	95	109	109	125	125	155	155	174	
Packed Weight	kg	105	119	119	140	140	175	175	194	



Heat pump
Heating and cooling

Monoblock Heat Pump / Heating & Cooling&DHW / DC Inverter / Residential Type



Heat pump
Heating and cooling



Features:

- R290 refrigerant, low GWP (GWP=3)
- Energy class: A+++
- Heating+Cooling+DHW
- Full DC inverter compressor and fan motor
- -30°C inverter
- WIFI smart control
- Outlet water temperature up to 75°C



Application

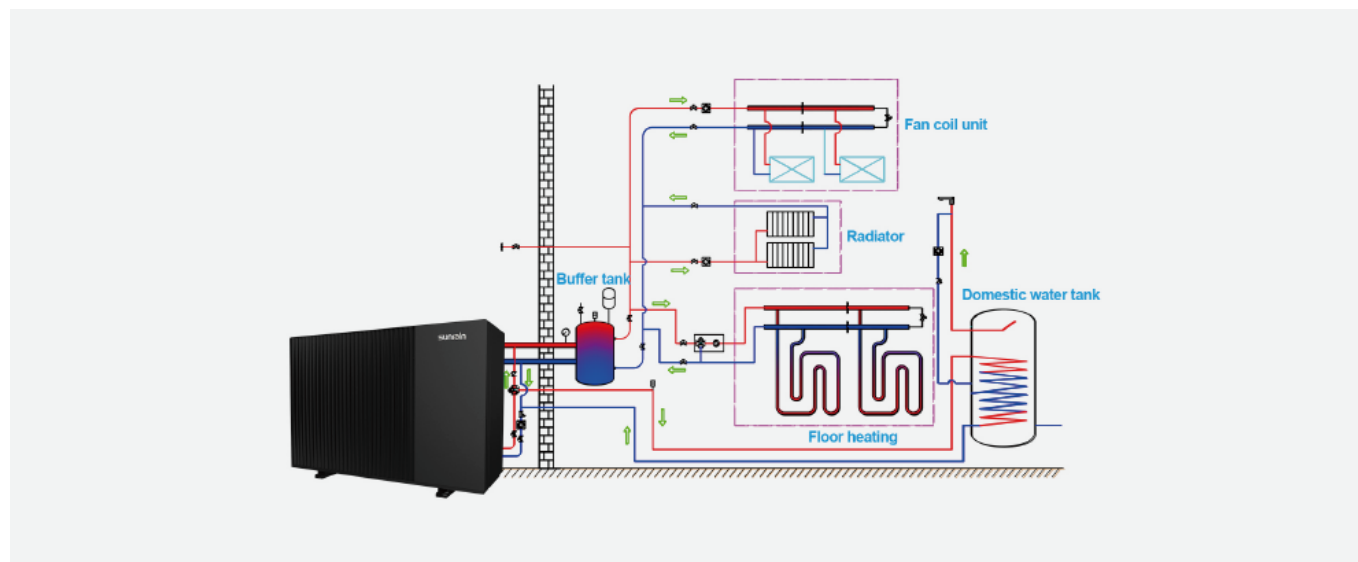

Technical Data

Photos							
Model		BLN-006TC1	BLN-012TC1	BLN-012TC3	BLN-018TC1	BLN-018TC3	
Power supply	V/Ph/Hz	220~240/1/50	220~240/1/50	380~415/3/50	220~240/1/50	380~415/3/50	
Nominal Heating (Max) (A7/6°C, W30/35°C)	Heating Capacity	kW	3.0~9.1	5.5~15.1	5.5~15.1	7.5~22.1	7.5~22.1
	Power Input	kW	0.65~2.29	1.08~3.9	1.08~3.9	1.5~6.8	1.5~6.8
	Current Input	W/W	2.8~9.1	4.5~17.0	1.8~6.9	6.9~31.1	2.7~12.3
Nominal Heating (Max) (A7/6°C, W47/55°C)	Heating Capacity	kW	2.85~8.50	5.0~13	5.0~13	7.0~18.9	7.0~18.9
	Power Input	kW	0.95~2.85	1.75~4.96	1.75~4.96	2.15~7.35	2.15~7.35
	Current Input	W/W	2.9~9.2	4.6~17.1	1.9~7.0	7.0~31.3	2.8~12.4
Nominal Cooling (Max) (A35/24°C, W12/7°C)	Cooling Capacity	kW	1.25~5.8	3.65~10.2	3.65~10.2	4.5~17.7	4.5~17.7
	Power Input	kW	0.65~2.35	1.12~4.16	1.12~4.16	1.80~7.30	1.80~7.30
	Current Input	W/W	2.9~10.4	4.8~17.3	2.0~7.8	7.8~32.4	3.3~12.9
ERP Level (Outlet water temp. at 35°C)	/	A+++	A+++	A+++	A+++	A+++	
MAX. input power	kW	3.00	5.50	5.50	7.50	9.00	
MAX. input current	A	13.50	24.50	10.50	35.00	16.00	
Refrigerant	/	R290	R290	R290	R290	R290	
Rated water flow	m³/h	1.00	1.80	1.80	3.00	3.00	
Fan quantity	/	1	1	1	2	2	
Fan motor type	/	DC inverter					
Compressor	/	DC inverter					
Circulating pump	/	Inverter type / Built-in					
IP Class	/	IPX4					
Sound pressure at 1m distance	dB(A)	42	44	44	48	48	
Max outlet water temperature	°C	75	75	75	75	75	
Water piping connections	/	DN 25 (1")	DN 25 (1")	DN 25 (1")	DN 32 (1-1/4")	DN 32 (1-1/4")	
Water Pressure drop(max)	kPa	20	25	25	60	60	
Operating temperature range (Heating mode)	°C	-30~45					
Operating temperature range (Cooling mode)	°C	16~45					
Unpacked Dimensions (L×D×H)	mm	1150×410×800	1285×455×930	1285×455×930	1285×455×1350	1285×455×1350	
Packed Dimensions (L×D×H)	mm	1300×485×950	1450×530×1050	1450×530×1050	1450×530×1450	1450×530×1450	
UnPacked Weight	kg	90	110	110	145	145	
Packed Weight	kg	115	125	125	160	160	



Heat pump
Heating and cooling

Monoblock Heat Pump / Heating & Cooling&DHW / DC Inverter / Residential Type



Heat pump
Heating and cooling



Heat pump
Heating and cooling

Features:

- Energy class: A++
- Heating+Cooling+DHW
- Full DC inverter compressor and fan motor
- -30°C inverter EVI
- WIFI smart control
- R32 refrigerant, environmental friendly
- Outlet water temperature up to 60°C



Application

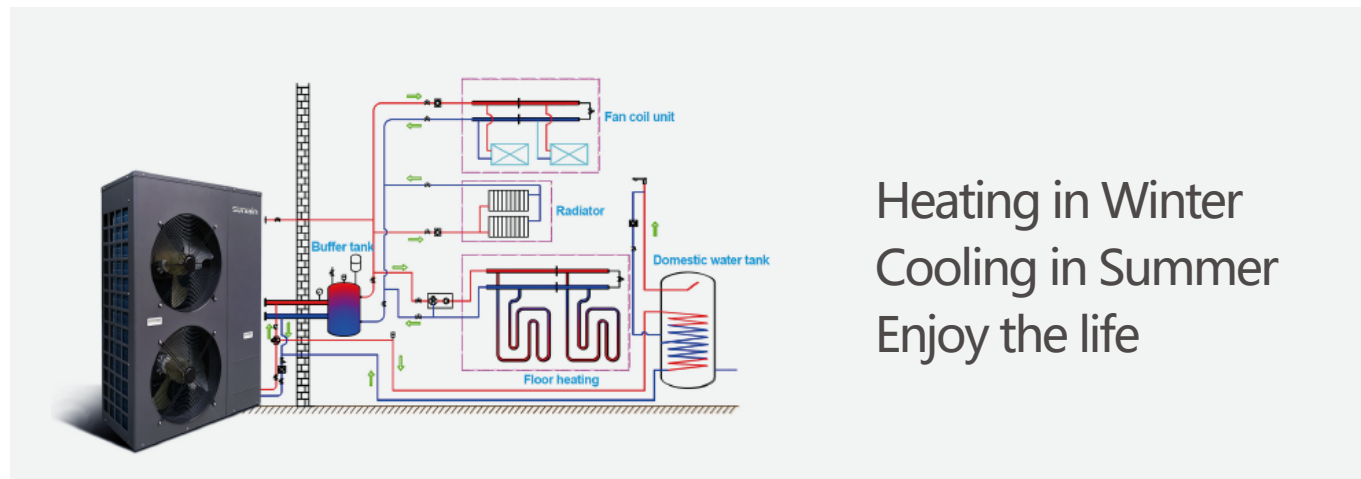

Heating in Winter
Cooling in Summer
Enjoy the life

Technical Data

Photos											
Model		BLN-009TA1	BLN-012TA1	BLN-015TA1	BLN-018TA1	BLN-012TA3	BLN-015TA3	BLN-018TA3	BLN-026TA3	BLN-032TA3	
Power supply	V/Ph/Hz	220-240/1/50				380-415/3/50					
Performance Condition: Outdoor air 7°C / 6°C, Inlet / Outlet water 30°C / 35°C											
Heating	Capacity	kW	3.4 ~ 10.2	4.6 ~ 12.8	5.2 ~ 16.8	6.8 ~ 20.5	4.6 ~ 12.8	5.2 ~ 16.8	6.8 ~ 20.5	11.8 ~ 28.6	14.5 ~ 36.3
	Rated input	kW	0.7 ~ 3.2	0.8 ~ 3.9	1.0 ~ 5.1	1.5 ~ 5.9	0.8 ~ 3.9	1.0 ~ 5.1	1.5 ~ 5.9	2.9 ~ 6.2	3.8 ~ 7.6
	SCOP		4.29	4.31	4.26	4.21	4.31	4.26	4.21	4.36	4.20
Performance Condition: Outdoor air 7°C / 6°C, Inlet / Outlet water 50°C / 55°C											
Heating	Capacity	kW	3.6 ~ 10.3	4.7 ~ 12.9	5.3 ~ 16.8	6.9 ~ 20.8	4.7 ~ 12.9	5.3 ~ 16.8	6.9 ~ 20.8	11.8 ~ 28.8	14.7 ~ 36.6
	Rated input	kW	0.9 ~ 4.3	1.4 ~ 5.1	1.3 ~ 6.7	2.0 ~ 7.7	1.4 ~ 5.1	1.3 ~ 6.7	2.0 ~ 7.7	3.8 ~ 8.1	4.9 ~ 9.9
	SCOP		3.36	3.30	3.32	3.65	3.30	3.32	3.65	3.69	3.52
Performance Condition: Outdoor air 35°C / 24°C, Inlet / Outlet water 12°C / 7°C											
Cooling	Capacity	kW	2.1-8.2	2.6 ~ 9.1	3.6 ~ 11.5	4.2 ~ 16.8	2.6 ~ 9.1	3.6 ~ 11.5	4.2 ~ 16.8	5.2 ~ 19.5	6.2 ~ 24.5
	Rated input	kW	1.4 ~ 5.2	1.9 ~ 6.1	2.0 ~ 7.8	2.8 ~ 8.9	1.9 ~ 6.1	2.0 ~ 7.8	2.8 ~ 8.9	4.8 ~ 9.3	5.1 ~ 11.4
	EER		2.82	2.77	2.86	2.98	2.77	2.86	2.98	2.83	2.96
Energy class (SCOP)	Outlet water temp. at 35°C		A++								
	Outlet water temp. at 55°C		A++								
Refrigerant	Type		R32								
	Charged volume	kg	1.7	1.8	3.5	3.6	1.8	3.5	3.6	5.5	7.5
Noise level	Heating	dB(A)	45	45	48	48	45	48	48	50	50
	Cooling	dB(A)	46	46	49	49	46	49	49	51	51
Water flow volume	m3/h	1.2	1.5	2.5	2.5	1.5	2.5	2.5	3.5	5.0	
Water piping connections	mm	DN25 Male			DN32 Male	DN25 Male	DN25 Male	DN32 Male	DN32 Male	DN40 Male	
Operating temperature range	Cooling	°C	-5 ~ 48								
	Heating	°C	-30 ~ 48								
	DHW	°C	-30 ~ 48								
Net dimensions (W*D*H)	mm	1005*375*800	1025*380*1320	1077*377*1460	1005*375*800	1025*380*1320	1077*377*1460	1127*427*1560			
Packed dimensions (W*D*H)	mm	1080*455*960	1076*440*1460	1150*450*1620	1080*455*960	1076*440*1460	1150*450*1620	1150*500*1720			
Net/Gross weight	kg	70/80	75/85	125/140	162/178	75/85	125/140	162/178	160/178	200/218	

Split Heat Pump / Heating & Cooling & DHW / DC Inverter / Residential Type



Features:

- Energy class: A++
- Heating+Cooling+DHW
- Full DC inverter compressor and fan motor
- -30°C inverter EVI
- WIFI smart control
- R410A refrigerant, environmental friendly
- Outlet water temperature up to 55°C



Application

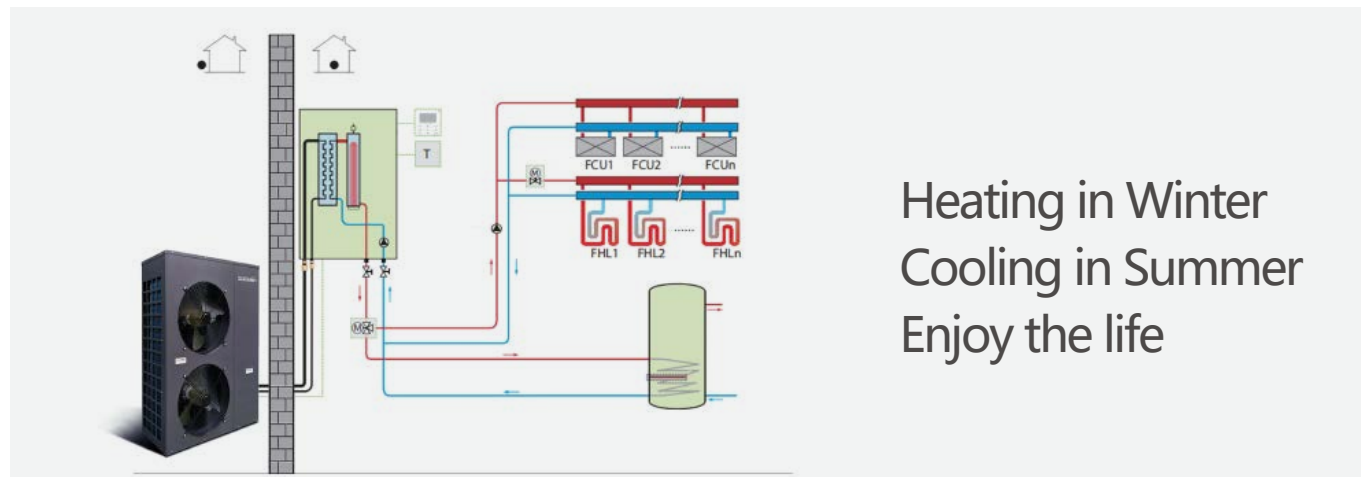

Heating in Winter
Cooling in Summer
Enjoy the life

Technical Data / Outdoor Unit

Photos				
Model		BLN-012TA1S	BLN-018TA1S	BLN-018TA3S
Power supply		V/Ph/Hz	220-240/1/50	
Performance Condition: Outdoor air 7°C / 6°C, Inlet / Outlet water 30°C / 35°C				
Heating	Capacity (min-max)	kW	4.3 ~ 12.3	6.7 ~ 20.5
	Rated input(min-max)	kW	0.7 ~ 3.8	1.5 ~ 5.9
	SCOP		4.31	4.21
Performance Condition: Outdoor air 7°C / 6°C, Inlet / Outlet water 50°C / 55°C				
Heating	Capacity	kW	4.5 ~ 12.5	6.8 ~ 20.6
	Rated input	kW	1.4 ~ 5.1	2.0 ~ 7.7
	SCOP		3.30	3.65
Performance Condition: Outdoor air 35°C / 24°C, Inlet / Outlet water 12°C / 7°C				
Cooling	Capacity	kW	2.5 ~ 9.1	4.2 ~ 16.5
	Rated input	kW	1.9 ~ 6.1	2.8 ~ 8.9
	EER		2.71	2.78
Energy class (SCOP)	Outlet water temp. at 35°C		A++	
	Outlet water temp. at 55°C		A++	
Refrigerant	Type		R410A	
	Charged volume	kg	2.3	4.3
Noise level	Heating	dB(A)	45	48
	Cooling	dB(A)	46	49
Operating temperature range	Cooling	°C	-5 ~ 48	
	Heating	°C	-30 ~ 48	
	DHW	°C	-30 ~ 48	
Net dimensions (W*D*H)		mm	1005*375*800	1077*377*1460
Packed dimensions (W*D*H)		mm	1080*455*960	1150*450*1620
Net/Gross weight		kg	66/76	125/138

Technical Data / Hydronic Box

Photos			
Model		Indoor Unit	
Power supply		V/Ph/Hz	
Dimension (W*H*D)		mm	
Packing (W*H*D)		mm	
Net/gross weight		kg	
Water circuit	Piping connections	mm	
	Total water volume	L	
	Drainage pipe	mm	
	Expansion tank	Volume	L
		Max water pressure	MPa
	Pressure relief valve	MPa	
	Water pump head	m	

Multi-function Heat Pump / Heating & Cooling / Commercial Type



Heat pump
Heating and cooling



Features:

- R410A refrigerant, environmental friendly.
- Higher water temperature output up to 55 °C.
- Adopt EVI technology, the operation ambient temperature can reach at -30 °C.
- High pressure protection.
- Defrost automatically.
- With MODBUS communication.
- Adapt intelligent controller, full automatically operation.
- Through different installation, the system can be used for cooling or heating.



MODBUS

Application

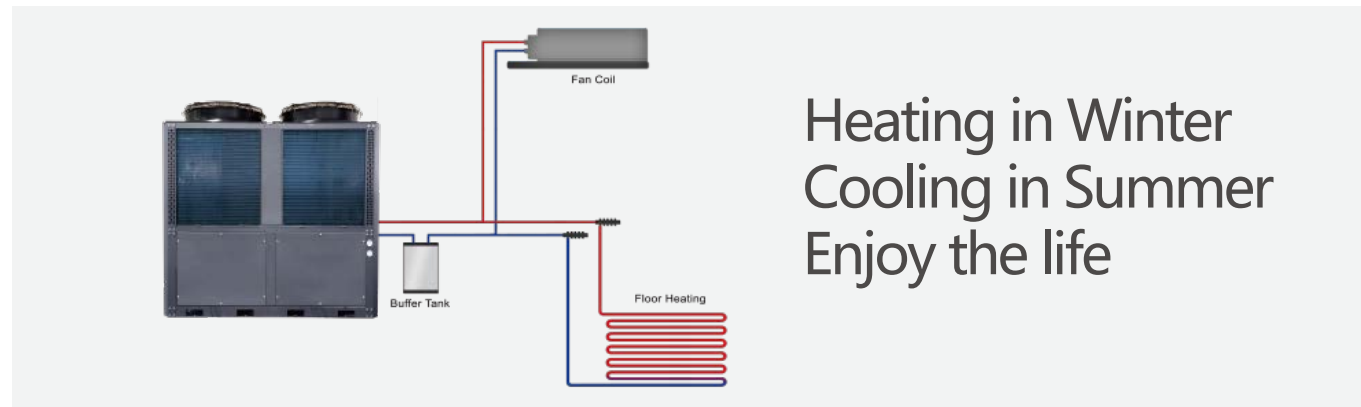

Heat pump
Heating and cooling

Technical Data

Photos				
Model No.	DLN-050TA1	DLN-100TA1	DLN-200TA1	DLN-400TA1
Power Supply	380~415V/3/50Hz	380~415V/3/50Hz	380~415V/3/50Hz	380~415V/3/50Hz
Heating Capacity at Air 7°C/6°C, Water 30°C in, 35°C out				
Heating Capacity (kW)	45	90	180	350
Power Input (kW)	10.3	20.8	42	81.4
COP	4.36	4.32	4.25	4.30
Heating Capacity at Air 7°C/6°C, Water 50°C in, 55°C out				
Heating Capacity (kW)	36	67	167	328
Power Input (kW)	15.5	25.48	56.7	113.9
COP	2.32	2.63	2.95	2.88
Heating Capacity at Air -12°C/-14°C, Water 50°C in, 55°C out				
Heating Capacity (kW)	24	40	107	205
Power Input (kW)	15.4	25	54	104.6
COP	1.55	1.60	1.98	1.96
Cooling Capacity at Air 35°C/24°C, Water 12°C in, 7°C out				
Cooling Capacity (kW)	30	60	140	268
Power Input (kW)	11.9	22.9	43.8	87.9
EER	2.53	2.62	3.19	3.05
Max Power Input (kW)	16.8	36.5	70.1	145.0
Max Current (A)	31.5	63.3	132.5	260.0
Compressor quantity	1	2	2	4
Expansion Valve	Saginomiya/EEV	Saginomiya/EEV	Danfoss/EEV	Danfoss/EEV
Air Flow Direction	Vertical	Vertical	Vertical	Vertical
Water Flow Volume(m³/h)	8	16	32	60
Water Pressure Drop	50kPa	50kPa	48kPa	50kPa
Dimensions(L*W*H) (mm)	1252*1076*1870	2198*1096*2176	2300*1150*2400	2800*2200*2450
Working temperature range (°C)	-30 ~ 48	-30 ~ 48	-30 ~ 48	-30 ~ 48
Noise (dB(A))	≤62	≤67	≤70	≤76
IP class	IPX4	IPX4	IPX4	IPX4
Net Weight (kg)	450	800	1330	2186
Water connection	DN 40	DN 50	Flange DN 80	Flange DN 100

Successful Cases





sunrain

Heating in Winter
Cooling in Summer
Enjoy the life